

STANDARD LEASE APPLICATION: NON-DISCHARGE

1. APPLICANT CONTACT INFORMATION

Applicant	Kenneth Curtis Sparta		
Contact Person	Kenneth Curtis Sparta		
Address	3 Coffin Pond Rd		
City	Freeport		
State, Zip	Maine, 04032		
County	Cumberland		
Telephone	207-841-9911		
Email	SPARTANDIVESERVICES@gmail.com spartanseafarms@gmail.com		
Type of Application	<input checked="" type="checkbox"/> Draft Application [submitted before scoping session session]		<input type="checkbox"/> Final Application [submitted after scoping session]
Dates	Pre-Application Meeting: 12/15/2019	Scoping Session:	Draft Application Submitted:

Note: If applicant is a corporation or a partnership, the "Corporate Applicant Information Document" available at: <http://www.maine.gov/dmr/aquaculture/forms/standard.html> must also be completed.

2. PROPOSED LEASE SITE INFORMATION

Location of Proposed Lease Site	
Town	Freeport
Waterbody	Casco Bay
General Description (e.g. south of B Island)	West of Crab Island
Lease Information	
Total acreage requested (100-acre maximum)	8.25
Lease term requested (20-year maximum)	20 years
Type of culture (check all that apply)	<input checked="" type="checkbox"/> Bottom (no gear) <input checked="" type="checkbox"/> Suspended (gear in the water and/or on the bottom)
Is any portion of the proposed lease site above mean low water?	<input type="checkbox"/> Yes <input checked="" type="checkbox"/> No

Note: If you selected yes, you need to complete the steps outlined in the section titled: "19. Landowner/Municipal Permission Requirements".

3. WATER QUALITY

Directions: Water Quality Information can be found here: <http://www.maine.gov/dmr/shellfish-sanitation-management/closures/pollution.html>

Pollution Area (e.g. "19-A"):	none 15
Pollution Area Section (e.g. "B.2". or "none"):	none
Water Quality Classification (e.g approved, restricted, etc.):	approved

Note: If you are proposing to grow molluscan shellfish in waters classified as anything other than open/approved, you will need to contact the Bureau of Public Health to discuss you plans at the following email: DMRPublicHealthDiv@maine.gov

4. SPECIES INFORMATION

A. Please complete the table below and add additional rows as needed.

Name of species to be cultivated (include both common and scientific names):	Name and address of the source of seed stock, juveniles, and/or smolts	Maximum number (or biomass) of organisms you anticipate on the site at any given time
1. American Eastern Oyster <i>Crassostrea Virginica</i>	Thomas Henniger Yarmouth, Maine	1,200,000
2. European Oyster <i>Ostrea Edulis</i>	Wild spat collection from site	300,000
3. Sea Scallop <i>Placopecten Magellanicus</i>	Dan Harriman Cape Elizabeth, Maine	300,000
4. Quahog <i>Mercenaria Mercenaria</i>	Muscongus Bay Aquaculture Bremen, Maine	300,000
5. Algae Kelp <i>Laminariales</i>	University of New England Saco, Maine	45,000 lbs

Saccharina LATISSIMA + Saccharina LATISSIMA forma ARGENTISSIMA

B. Do you intend to possess, transport, or sell whole or roe-on scallops? Yes No

If you answered "yes" please contact the Bureau of Public Health to discuss you plans at the following email: DMRPublicHealthDiv@maine.gov

Note: If you are proposing to grow molluscan shellfish, this application also serves as your written operational plan as required in the National Shellfish Sanitation Program (NSSP) Model Ordinance Chapter 2, and must be maintained in your files. If you wish to submit an operational plan separate from this application, please contact: DMRPublicHealthDiv@maine.gov

5. VICINITY MAP

Note: Please label as: 'Vicinity Map'.

Directions: Using a NOAA Chart or USGS topographic map, show the area within a minimum of one-half mile of the proposed lease site.

The map needs to display the following:

- The waters, shore lands, and lines of mean high and mean low water within the general area of the lease
- An arrow indicating true north
- A scale bar
- The approximate lease boundaries

6. BOUNDARY DRAWING

Note: Please label as: 'Boundary Drawing'.

Directions: Depict the boundaries of the proposed lease site. Provide a drawing with all corners, directions, and distances labeled. Provide coordinates for each corner as follows:

- Coordinate Description
Provide geographic coordinates for each corner of the lease site in latitude and longitude as accurately as possible (e.g., to the nearest second or fraction of a second). Identify the datum from the map, chart, or GPS unit used to develop these coordinates. The datum will be shown on the map or chart you are using. The Coordinate Description may be provided separately from the Boundary Drawing.

7. SITE DEVELOPMENT

Directions: If your operations require the use of cages, nets, ropes, trays, or any object (structure) other than the organism to be grown directly on the bottom or buoys to mark the corners of the lease site, you must submit gear drawings and maximum structure schematics (information below). This section is intended to provide accurate plans depicting the physical structures to be placed in the proposed area. All dimensions need to be labeled with the appropriate units (i.e. 10ft, 10in). If you are proposing a bottom lease (no gear), please skip to question “F. Marking”.

Note: You may embed the schematics within the document, or attach them to the end of your application. If you attach the schematics, please label them according to the instructions provided below.

A. Gear Information

Directions: Include a drawing of an individual piece of gear for each of the gear type(s) you plan to use. Include units referenced (i.e. 10in, 10ft, etc.).

1. Gear Drawing: Please include the following for each gear type that will hold organisms to be cultured (e.g. Polar circles, marine algae longlines, oyster cages) and label as “Gear Drawing”. This view must show the following:
 - Length, width, and height of each gear type.
2. Gear Table: List and describe each individual gear type that you will use in the table below. Only include gear that will hold organisms to be cultured (e.g. Polar circles, marine algae longline, oyster cages).

Specific Gear Type	Dimensions	Time of year gear will be deployed	Maximum amount of this gear type that will be deployed on the site	Species that will be grown using this gear type
Oyster Gro Cages	36"x54"x32"	Year Round	240	oysters
Floating Oyster Bags	32"x22"x3"	Spring to Fall	160	oysters
Oyster Bottom Cages	36"x44"x32"	Year Round	96	oysters
Scallop Lantern Nets	60"x24"x24"	Spring to Fall	36	scallops
Scallop Cars	23"x15"x48"	Year Round	120	scallops
Quahog Bottom Bags	32"x22"x3"	Year Round	500	Quahog
Kelp Long Lines	3/8" X 500 feet	Winter	12	Algae

500
KCS

B. Maximum Structure and Mooring System Schematic

Directions: Include drawings of your maximum gear layout. Include units referenced (i.e. 10in, 10ft, etc.).

1. Overhead View. Please include the following and label as “Overhead View”:
 - Maximum layout of gear, including moorings.
 - Length and width of project.
 - Approximate spacing between gear.
 - Lease boundaries and the location of proposed corner markers and any additional gear markers that would be present.

2. Cross-Section View. Please include the following and label as “Cross-Section View”:
 - The sea bottom.
 - Profile of gear in cross-section as it will be deployed.
 - Label gear with dimensions and materials.
 - Show mooring gear with mooring type, scope, hardware, and line type and size.
 - Depth of gear in relation to the water’s surface at mean low water and mean high water (if applicable).

Note: Please include an additional Cross Section View, depicting the elements listed below, if there will be seasonal changes to gear layout (i.e. over wintering).

C. On-Site Support Structures

1. Describe structures such as barges, sheds, etc., to be located on-site. Provide a schematic and indicate the dimensions, including height above sea level, materials, etc.
NONE

2. Describe the storage and use of oil, gasoline or other hazardous materials on this facility. If petroleum products are to be stored on site, provide a spill prevention plan.
NONE

D. Gear Color

Provide the color of the gear and structures proposed to be used at the lease site.
All perimeter marking buoys will be yellow and will have SOLAS reflective tape. All flotation buoys within the farm will be yellow. Oyster cages and Oyster bags and their flotation will be black.

E. Equipment Layout

Provide schematic or photographic renderings of the generalized layout of the equipment as depicted from two vantage points on the water. Provide the locations of the two vantage points.

F. Marking

Will you be able to mark your site in accordance with DMR regulations, Chapter 2.80? <input checked="" type="checkbox"/> Yes <input type="checkbox"/> No If you answered no, explain why and suggest alternate markings.
n/a

Note: If a lease is granted, you will also be required to mark the site in accordance with appropriate US Coast Guard Regulations. If you have questions about US Coast Guard Regulations contact: 1st Coast Guard District, Aids to Navigation Office ((617)-223-3293).

8. PRODUCTION ACTIVITIES

Directions: If you are cultivating more than one species, you will need to provide information for each species. Please attach additional pages if needed.

A. Please explain your proposed seeding activities. What months will seeding occur and how often will you be onsite to seed during this time.

Oyster quahog and Scallop seed and spat will be added weekly in June July and August. Oysters will be seeded on the bottom in September of each year. Algae lines will be seeded in November and December.

B. Please explain your proposed tending/maintenance activities.

Cages and lines will need to be tended weekly. We know that there will be a constant need to replace hardware and lines to ensure that all of our gear remains on the farm where it belongs.

C. How frequently will you visit/tend the site for routine tending/maintenance (i.e. flipping cages, etc.)?

We will flip oyster cages and bags every week.
Oysters will be tumbled offsite monthly in July, August, and September.
Scallop lantern nets will be emptied and switched to clean nets once every summer.
Quahog bags will be picked up and washed every 2 weeks.
Algae lines will have buoys or weights added every week to ensure they are at the correct height to grow.

D. Describe the harvesting techniques you will use. If you plan on using a drag, please provide the dimension

Oysters will be harvested from Oyster-Gro Cages on the surface and bottom cages.
Scallops will be harvested from Scallop Cars. They will be shucked onsite until testing is less expensive. At that point some will be for the half shell market.
Quahogs will be harvested from the bags they are grown in and washed on the boat.
Diploid oysters will be hand harvested from the bottom by divers.
All product will be put on ice on the boat asap.

E. How often will you be at the site during harvesting periods?

We will harvest year round 2-4 days per week.

F. Will gear be on the site year-round? Yes No

G. If no, please describe any overwintering or “off season” plans for the site. For example, will you remove gear from the site and/or deploy gear in different areas within the proposed site? Please include where gear or product will be located if removed from the site.

A portion of the site which is in the channel that runs west of crab toward Winslow park will be utilized in the winter. This will be used for winter storage of our oyster gro cages and to grow algae.

From May 15 to October 15 all gear will be removed from this portion of the lease

9. NOISE AND LIGHT

Directions: If a question does not pertain to your proposed operations, please write “not applicable” or “N/A.”

A. What type of boats will be used on the site? When and how often will these vessels be on site?

We will be using a 23’ welded aluminum skiff with a 4stroke outboard motor and a 13’ fiberglass skiff with a 4stroke motor. These boats will be on the site daily.

B. What type of powered equipment (e.g. generator, power washer, grading equipment, barges, etc.) will be used on the site? When and how often will the equipment be used?

We will use a Honda powerpack to run our hydraulic pothauler to lift equipment in the spring. This will be used for approximately 4 days.

C. Specify how you intend to reduce noise levels from the boats and other powered equipment.

We have purchased Yamaha 4-stroke motors for our boats so that they will be quiet. I will put a box with sound deadening foam around our Honda powerpack to deaden noise for the 4 days we use it.

D. Provide the number, type (whether fixtures are shielded), wattage and location of lights, other than those used for navigation or marking, that will be used at the proposed lease site.

No other lights would be used.

E. Indicate under what circumstances you might work at your site beyond daylight hours.

Only in an emergency (e.g. impending storm).

10. CURRENT OPERATIONS

Directions: If a question does not pertain to your proposed operations, please write “not applicable” or “N/A.”

A. Describe your existing aquaculture operations.
I have 4 4X100 LPAs that have 300,000 oysters and 50,000 scallops. I also have been working with other farmers to grow kelp.

B. What are your plans for any existing leases and/or Limited Purpose Aquaculture (LPA) licenses if the lease is granted? Will any existing leases and/or LPA licenses be relinquished if the lease is granted? If so, please indicate which ones.
I will continue to use KCSP219 off of Wolfes Neck to work with new species and grow out methods. I will relinquish KCSP119, KCSP319, & KCSP419.

11. ENVIRONMENTAL CHARACTERIZATION

Directions: Using your knowledge of the area, describe the environment of the proposed lease site. Be sure to include units of measurement in your answers (i.e. feet, cm/s).

A. What are the approximate depths at mean low water?
Between 1 and 14 feet.

B. What are the approximate depths at mean high water?
Between 9 and 23 feet.

C. Provide the approximate current speed and direction during the ebb and flow.
Ebb and flow runs between 0 and 1.4 knots in a predominatelt SSW and NNE direction.

D. The following questions (D.1 through D.6) may be answered in writing or by submitting a video. If you plan to submit a video, please contact the Department prior to video collection.

1. What are the bottom characteristics (mud, sand, gravel, rock, ledge or some mix, etc.)?

Most of the bottom is shell and mud with some mix of gravel in the channel on the north end of the lease.

2. Describe the bottom topography (flat, steep rough, etc.).

Flat with a slope into the Channel at the Norther end of the Lease

3. Describe marine organisms by species or common names. Based on your personal observations or other sources of information, are these species abundant, common, or rare?

Crabs - abundant
Lobsters - rare
Sculpin - rare
Rock Gunnels - rare
European oysters - rare
Hard Clams - rare

4. Are there shellfish beds or fish migration routes in the surrounding area? If so, please describe.

There are some European oysters in the area. Few are seen on the lease. Local lobstermen feel that lobsters use the channel on the northern end of the lease to move into the shallows around Lanes to Stockbridge Point. That is why this channel will be empty of gear during the time that lobsters will be moving.

5. Describe the presence and extent of submerged aquatic vegetation, i.e. eelgrass, within the proposed lease area. Please include the date of this observation along with the method of observation. If submerged aquatic vegetation is observed, please also describe the abundance below and sketch the limits of the beds in the vicinity map.

There is some eelgrass in the shallow southern end of the lease. It is very sporadic. It becomes more dense 300 yards SE of the proposed lease

6. Describe the general shoreline and upland characteristics (rocky shoreline, forested, residential, etc.)

The nearest shoreline is 1800' to the NE of the proposed lease on Crab Island. It is scrubby with a cobble beach and ledge. There is one summer cottage on the island.

E. Is your proposed lease located within a Maine Department of Inland Fisheries and Wildlife designated Essential Habitat?

Yes No

Note: The location of Essential Habitats in the State of Maine, along with information on how projects within these areas are reviewed, can be found here: <https://www.maine.gov/ifw/fish-wildlife/wildlife/endangered-threatened-species/essential-wildlife-habitat/index.html>

If a project is located within an Essential Habitat, applicants are strongly encouraged to contact the MDIFW Environmental Review Coordinator (John.Perry@maine.gov, phone: 207-287-5254) prior to application submission.

12. EXISTING USES

<p>A. Describe the existing uses of the proposed area in questions A.1 through A.5 below. Please include the a) type; b) time of year the activity occurs; c) frequency; and d) proximity to the lease site.</p>
<p>1. Commercial Fishing</p> <p>I closely monitored the lobster pots near my LPAs in 2019. During that time only two pots were observed in the proposed lease. Both were in the northern channel during the summer. This area will be clear of all gear during the summer months.</p>
<p>2. Recreational Fishing</p> <p>None observed on site</p>
<p>3. Boating Activities (please also include the distance to any navigable channel(s) from your proposed site at low water).</p> <p>Very little observed in the area. There is a channel that runs from west of Crab toward Winslow Park. This channel will be clear of all gear from May 15 to October 15.</p>
<p>4. Riparian Ingress/Egress</p> <p>The owners of Crab Island use the Eastern shore for their wharf out and mooring. The proposed lease will not interfere with their ability to reach their cottage.</p>
<p>5. Other uses (kayaking, swimming, etc.):</p> <p>I have never seen a kayaker or swimmer near my proposed lease site.</p>

<p>B. Are there private docks, moorings, or other access points within 1,000 feet of the proposed lease? If yes, please include approximate distance from proposed lease.</p>
<p>NONE</p>

C. Are there public beaches, parks, docking facilities or federally, state, or municipally conserved lands within 1,000 feet of the proposed lease site? If yes, please describe and include approximate distances from proposed lease.

NONE

13. EXCLUSIVE USE

If your lease is granted, what activities would you request be excluded from occurring within the boundaries of the lease site? In your answer please address applicable commercial and recreational fishing, boating activities, and other activities you listed in the 'Existing Uses' section of this application.

I would like all dragging to cease on my site.
Other than that I am happy to have folks around and in my site as long as my gear and crops are not damaged or molested.

14. RIPARIAN LANDOWNERS AND SITE ACCESS

A. If your lease is within 1,000ft of shorefront land (which extends to mean low water or 1,650 ft. from shore, whichever is less), the following supporting documents are required:

1. A labeled copy of a tax map(s) depicting the location of the proposed lease site and including the following elements:
 - Label the map “Tax Map: Town of (name of town).”
 - Legible scale
 - Tax lot numbers clearly displayed
 - The boundaries of the proposed lease
2. Please use the Riparian Landowner List (included on the next page) to list the name and address of every shorefront landowner within 1,000ft of the proposed lease site. Have the tax collector or clerk of the municipality certify the list.
3. If any portion of the site is intertidal, you need to complete the steps outlined in the section titled: “19. Landowner/Municipal Permission Requirements”.

B. Will your access to the lease area be across riparian land? <input type="checkbox"/> Yes <input checked="" type="checkbox"/> No
--

Note: If you selected yes, you will need to complete the landowner permission requirements included in “19. Landowner/Municipal Permission Requirements” of this application.

C. How will you access the proposed site? By boat from South Freeport.
--

D. How will your proposed activities affect riparian ingress and egress? They will not affect ingress or egress.
--

RIPARIAN LANDOWNER LIST

****THIS LIST MUST BE CERTIFIED****

On this list, please show the current landowners' names and mailing addresses as listed in the municipal tax records for all riparian shorefront parcels within 1,000 feet of the proposed lease site along with the map and lot number for each parcel. **It is the applicant's responsibility to assemble the information for the Town Clerk to certify.** The Town Clerk *only* certifies that the information is correct according to the Town's records. Once you have completed the form, ask the Town Clerk to complete the certification section below. If the parcels are within more than one municipality, provide a separate, certified riparian list for each municipality.

TOWN OF: Freeport

MAP #	LOT #	Landowner name(s) and address(es)
		<u>No one is within 1000'</u>

Please use additional sheets if necessary and attach hereto.

CERTIFICATION

I, n/a, Town Clerk for the Town of Freeport certify that the names and addresses of the property owners listed above, as well as the map and lot numbers, are those listed in the records of this municipality and are current as of this date.

SIGNED: n/a **DATE:** n/a

15. TECHNICAL CAPABILITY

Provide information regarding professional expertise. Attaching resume or documentation of practical experience necessary to accomplish the proposed project would satisfy this requirement.

I am a graduate of the Shared Waters program.
I spent 15 years as a working Registered Maine Kayaking and tidal fishing guide in Freeport waters.
I attended the USNA in Annapolis, MD.
I grew up on the water in Casco Bay being taught by my dad, a graduate of MMA.

16. FINACIAL CAPABILITY

A. Financial Capability

Please provide documentation to demonstrate you have the financial resoures to implement the proposal. For example, you may submit a letter from a financial instiution or funding agency indicating that you have an account in good standing, or their willingness to commit funds.

Note: Any financial information you submit with your application is part of the public record. Please exercise discreation when submitting financial information.

I currently own all of my gear and equipment and boat outright. I have prepaid for the moorings for my site. I have purchased my gear and equipment for 2020. I have also bought my oyster quahog and scallop seed for 2020 and my oyster seed for 2021. In addition I will be harvesting kelp, scallops, and oysters in 2020 to provide income above my current job. There is significant equity in my boat as it is a 2019 welded aluminum Lowell Skiff with a 2019 4stroke 115HP Yamaha should a loan be required in the future.

B. Cost Estimates

Please provide cost estimates of the proposed aquaculture activities.

My 2020 expenses except fuel (estimated to be \$1750) have already been paid. In 2021 I will be purchasing 24 oyster-gro cages, 24 bottom casges , 248 oyster bags, and 50,000 quahog seeds. This expenditure will be approx. \$12,000.

17. ESCROW ACCOUNT OR PERFORMANCE BOND

Check the category that describes your operation:

Check Here	Lease Category	Amount of Required Escrow or Performance Bond
	No gear/structure, no discharge	None
	No gear/structure, discharge	\$500.00
X	≤ 400 square feet of gear/structure, no discharge	\$1,500.00
	>400 square feet of gear/structure, no discharge	\$5,000.00*
	Gear/Structure, discharge	\$25,000.00

*DMR may increase the bond/escrow requirements for leases with more than 2,000 square feet of structure.

I, (printed name of applicant) KEN SPARTAN have read DMR Aquaculture Regulations Chapter 2.64(10) (D) and if this proposed lease is granted by DMR, I will either open an escrow account or obtain a performance bond, in the amount determined by the lease category.

 Applicant Signature

2/7/2020
 Date

Note: Add title if signing on behalf of a corporate applicant.

ADDITIONAL APPLICANTS: Each applicant must sign this section indicating that they will open an escrow account or obtain a performance bond. Use the space below for additional persons listed on the application. You may attach additional pages, if necessary.

I, (printed name of applicant) _____ have read DMR Aquaculture Regulations Chapter 2.64(10) (D) and if this proposed lease is granted by DMR, I will either open an escrow account or obtain a performance bond, in the amount determined by the lease category.

 Applicant Signature

 Date

Note: Add title if signing on behalf of a corporate applicant.

18. APPLICANT SIGNATURE PAGE

I hereby state that the information included in this application is true and correct. I have also read and understand the requirements of the Department's rules governing aquaculture and the application instructions pertaining to the standard lease process.

Printed name: KEN SPARTA

Title (if corporate applicant): _____

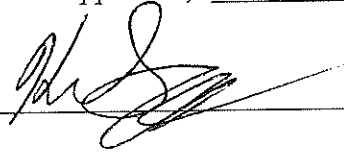
Signature:  Date: 2/7/2020

18 U.S.C. Section 1001 provides that: Whoever, in any manner within the jurisdiction of any department or agency of the United States knowingly and willfully falsifies, conceals, or covers up any trick, scheme, or disguises a material fact or makes any false, fictitious or fraudulent statements or representations or makes or uses any false writing or document knowing same to contain any false, fictitious or fraudulent statements or entry, shall be fined not more than \$10,000 or imprisoned not more than five years or both.

Note:

- All applicants must sign and date this page. Please use the space below, if additional signatures are required.
- Corporate applicants, please be sure to include the title(s) (i.e. President, Treasurer, etc.) of the individual(s) signing on the company's behalf.

Additional Applicant:

Printed name: _____

Title (if corporate applicant): _____

Signature: _____ Date: _____

19. LANDOWNER/MUNICIPAL PERMISSION REQUIREMENTS (if applicable)

Directions: If any portion of the site is intertidal, you need to complete the steps outlined below.

Step I: Obtain written permission from all intertidal landowners.

Pursuant to DMR Regulations Chapter 2.10(3)(G) the Department requires *written permission of every owner of intertidal land in, on, or over which the activity will occur.* It is your responsibility to obtain written permission and include it with your application materials. Please note that the Department does not provide forms for landowner permission.

Step II: Determine if the municipality where your site is located has a shellfish conservation program.

Pursuant to 12 MRSA §6072(3) *In any municipality with a shellfish conservation program under section 6671, the Commissioner may not lease areas in the **intertidal zone** within the municipality without the consent of the municipal officers.*

If the municipality where the proposed lease site is located has a shellfish conservation program, it is your responsibility to obtain consent for the proposed lease site from the municipal officers (i.e. the selectmen or councilors of the town, or the mayor and aldermen or councilors of a city.) Consent means a majority vote of the municipal officers as recorded in a public meeting.

It is your responsibility to contact the municipality and determine if they have a shellfish conservation program. Best practices would include discussing your plans with shellfish committee members, but only the consent of municipal officers is required.

Does the municipality, where the proposed site is located, have a shellfish conservation program? Yes No

If you answered yes, please attach documentation from a public meeting demonstrating that a majority of municipal officers have consented to your proposal.

APPLICATION SUBMISSION CHECKLIST

Please note: This checklist is provided for the applicant's reference and does not need to be returned with the application.

I. Content

- _____ Check for non-refundable application fee (\$500 for Draft Applications and \$1,000 for Final Applications), payable to *Treasurer State of Maine*.
- _____ **Newspaper Tearsheet** showing notification of scoping session (Draft Applications only)
- _____ **One (1) Vicinity map** with required items shown
- _____ **One (1) Boundary drawing** with required items shown
- _____ **One (1) Gear drawing** for each type of gear proposed
- _____ **One (1) Overhead view** depicting layout of gear from overhead
- _____ **One (1) Cross section view** depicting gear & moorings from the side for each gear configuration
- _____ **Tax map(s)**
- _____ **Riparian list**, certified (*if applicable*)
- _____ **Corporate applicant information document** and articles of incorporation or documentation of partnership (*if applicable*)

If any portion of the proposed lease site is above mean low water:

- _____ **Written permission** from all riparian landowners of the intertidal land on which the lease is proposed.
- _____ **Written consent** from the municipal officers (only required if the municipality has a shellfish conservation program).

II. Formatting

- _____ All pages (including attachments) are numbered sequentially
- _____ All attachments are clearly labeled and legible
- _____ Drawings and maps are legible, labeled properly, and include all required elements
- _____ All questions have been answered and signature pages signed
- _____ Please do not staple applications

Addendums

Vicinity Map

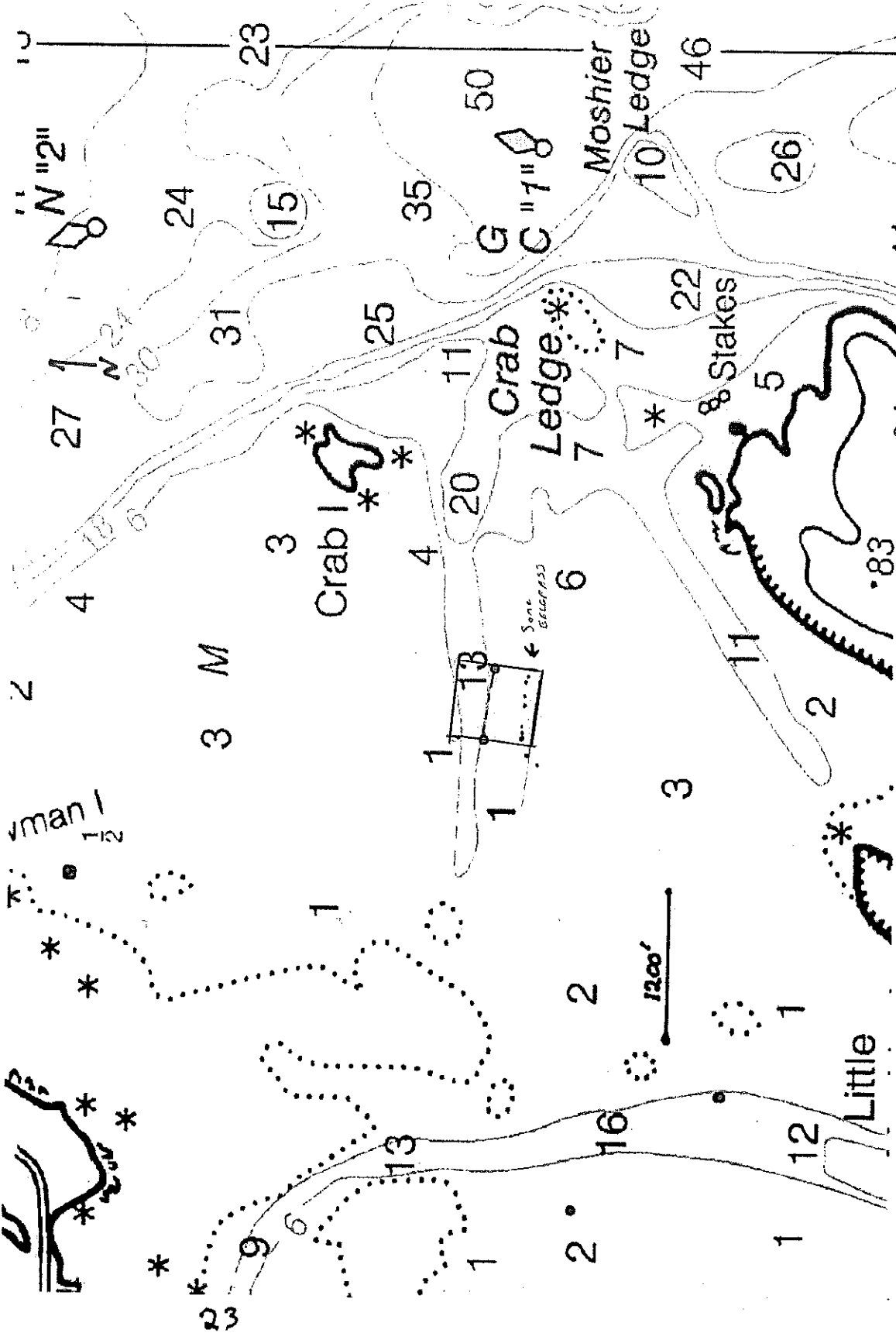

43560

4E

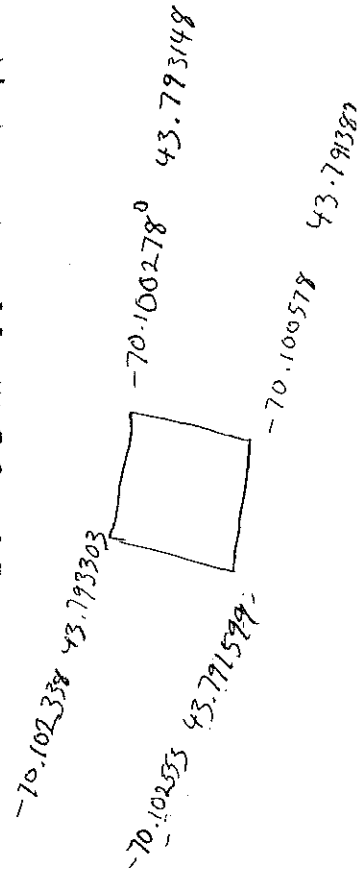

BOUNDARY DRAWING

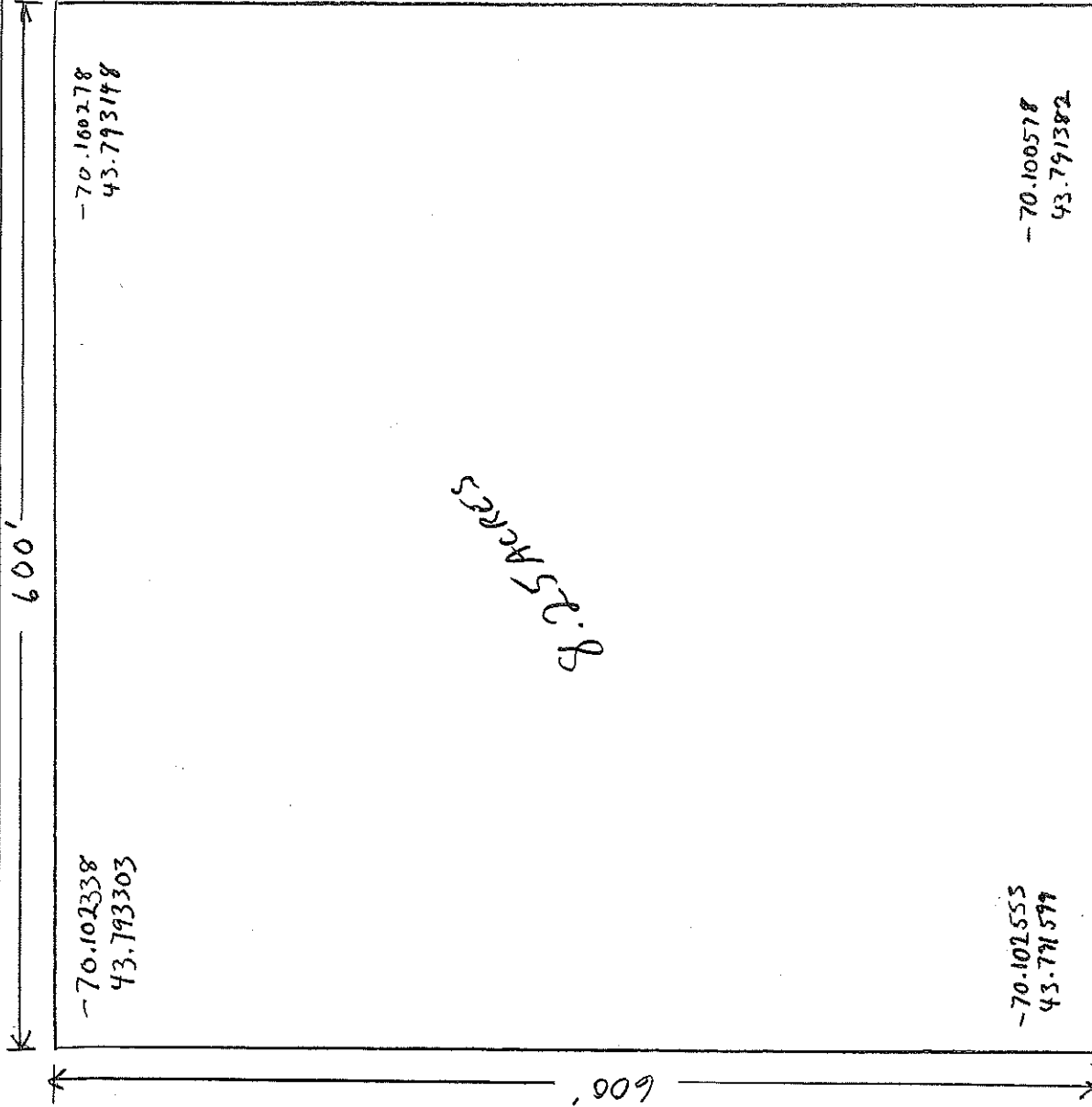

8.25 ACRES

PROPOSED LEASE
8.25 ACRES
600' X 600'

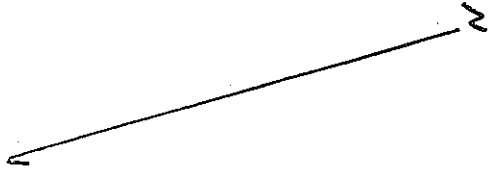

DMR AREAS USED
TO DETERMINE CORNERS

MOORING SCHEMATIC

SPRING to FALL

NO GEAR MAY 15 - OCTOBER 15

25

600'

288'

OYSTER GRO CAGES

250'

20'

15'

15'

15'

15'

15'

15'

15'

15'

15'

15'

15'

15'

15'

15'

15'

15'

15'

15'

15'

15'

15'

15'

15'

15'

15'

15'

15'

15'

15'

15'

OYSTER Bottom Cages

OYSTER BAGS

150'

SCALLOP Lantern Nets

SCALLOP CARS on Bottom

Quahog Bottom bags

600'

N

WINTERS OCTOBER 15 - MAY 15

26

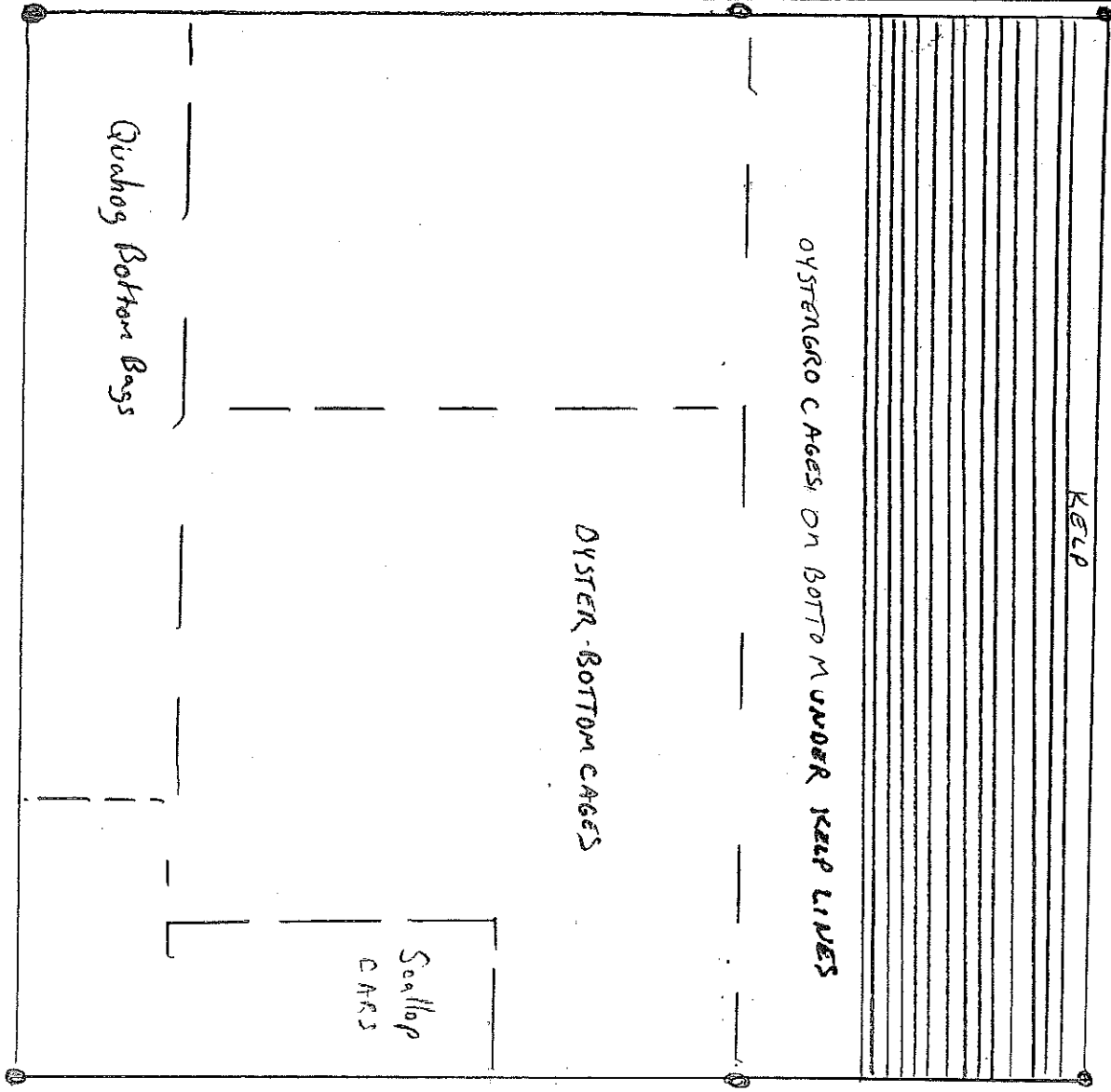

ALGAE LONG LINES

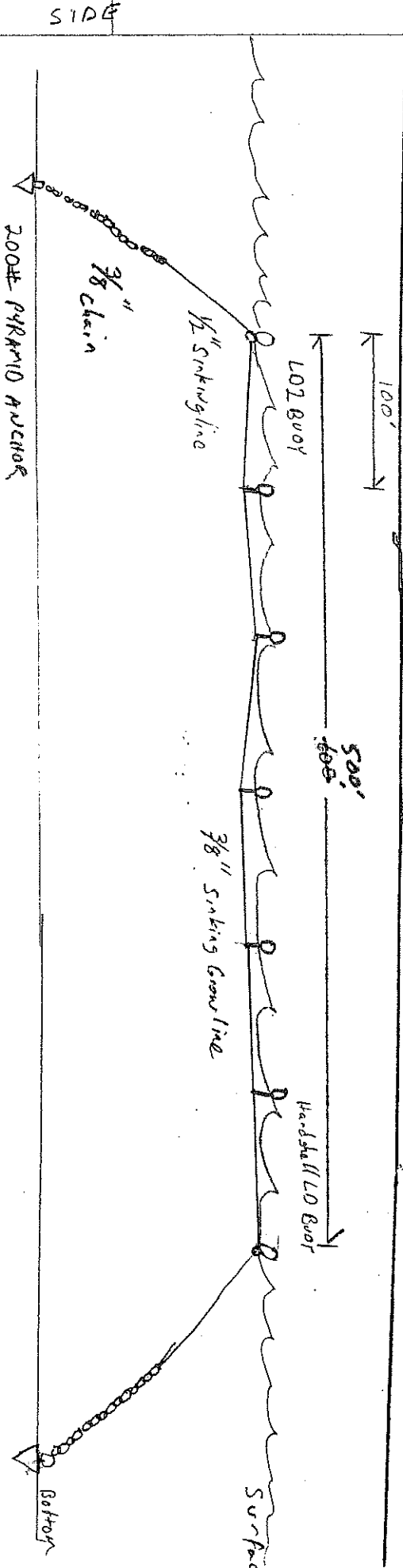

Nothing on Surface

↑ WINTER ↓
↓ Summer ↓

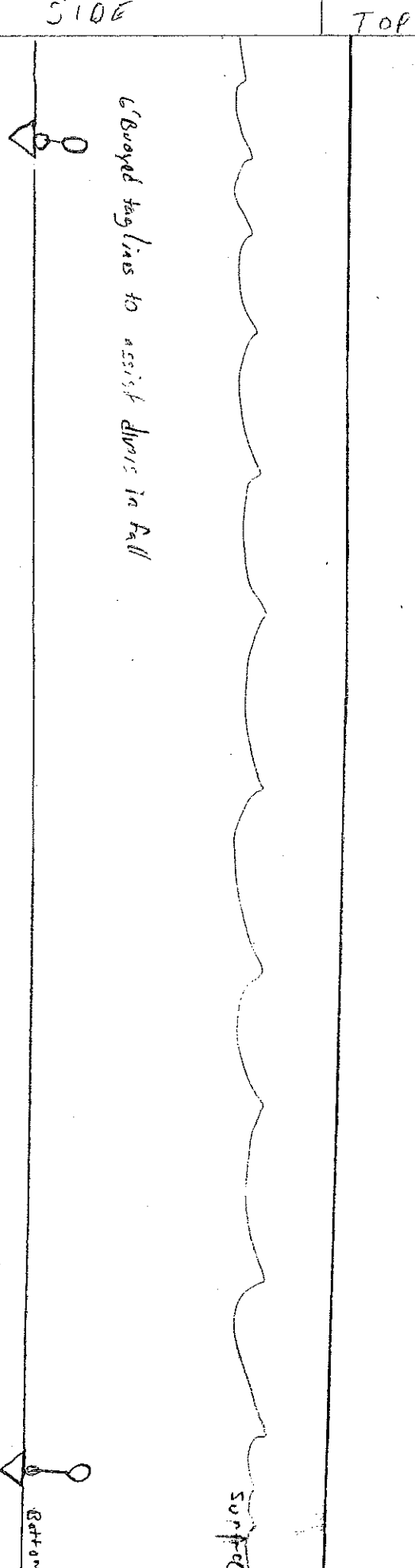

OYSTER BOTTOM CAGES

28

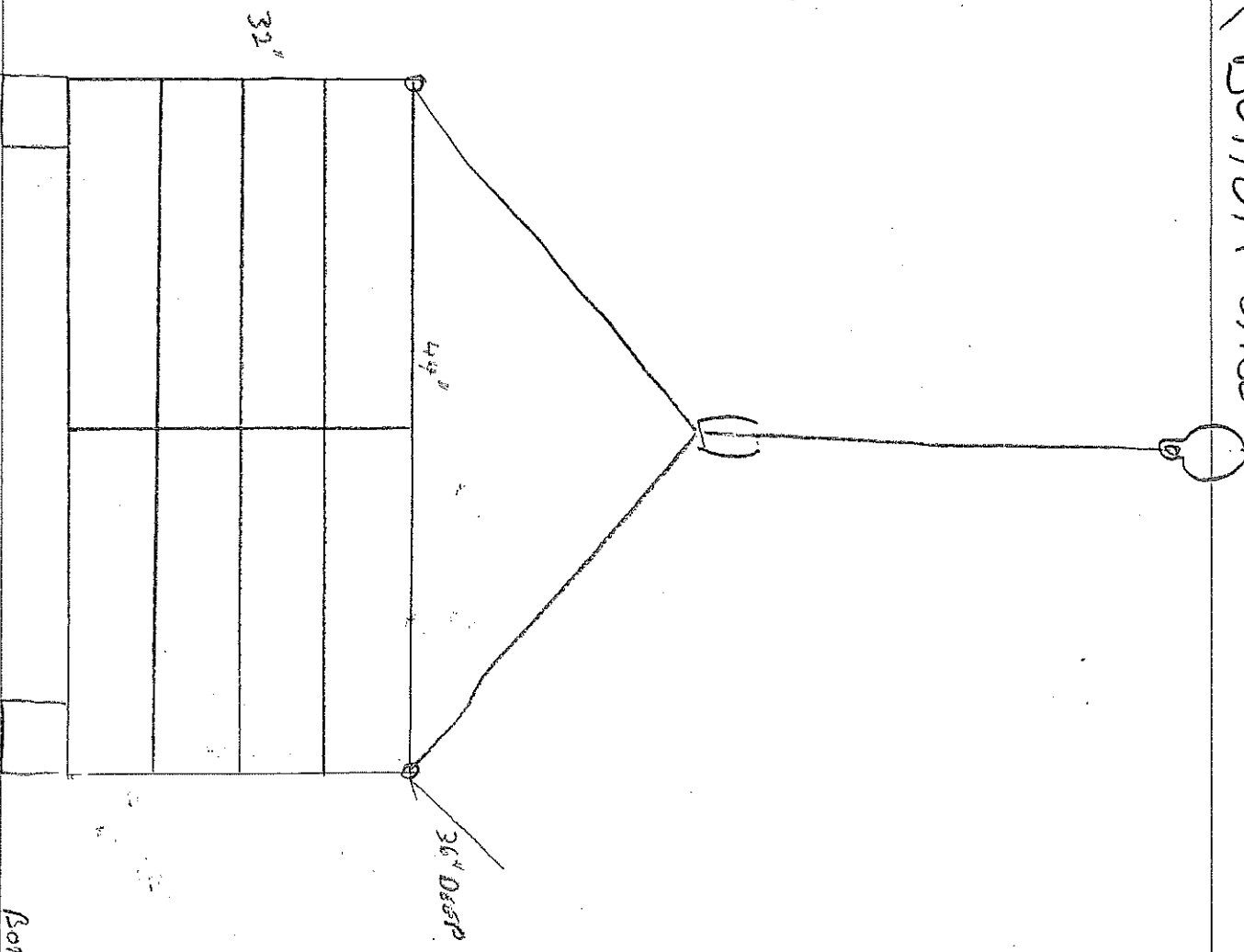

OYSTER BOTTOM CAGES
BUILT FROM 4X4 MARINE WIRE CAGE
EACH WILL HOLD 8 OYSTER BAGS
EACH CAGE WILL HOLD 2 1750
MARKET SIZE OYSTERS

28A

SYSTEM BOTTOM CAGES
Connected by pot warp in a string
each has a toggle seen at
low tide
each string has a high tide buoy

Top View

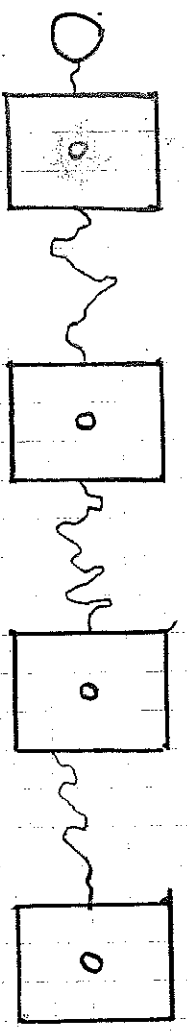

Side View

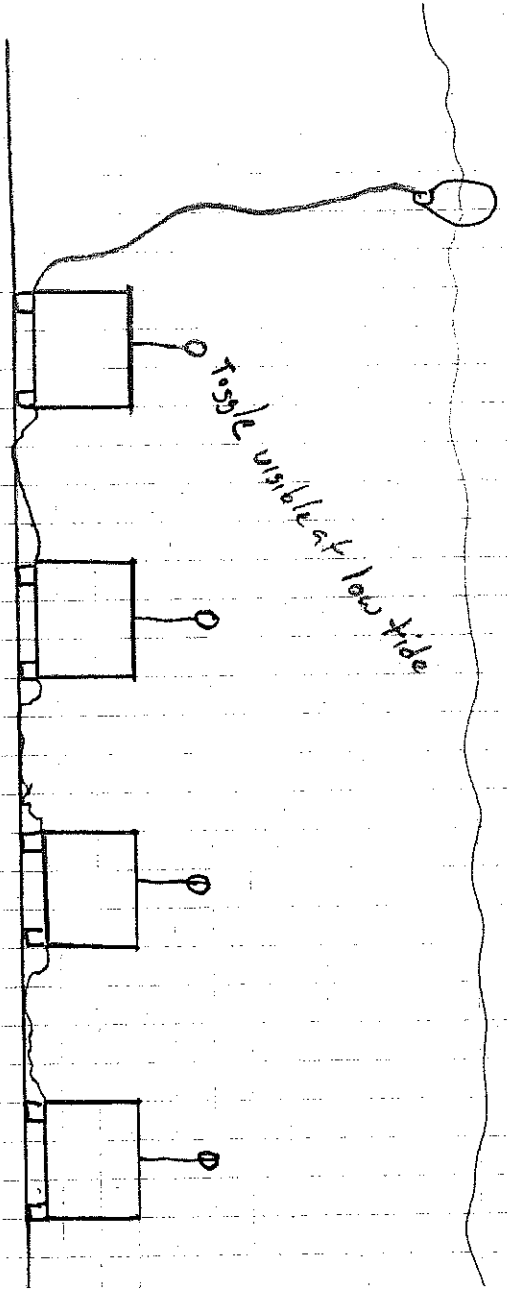

OYSTER GRO CAGES

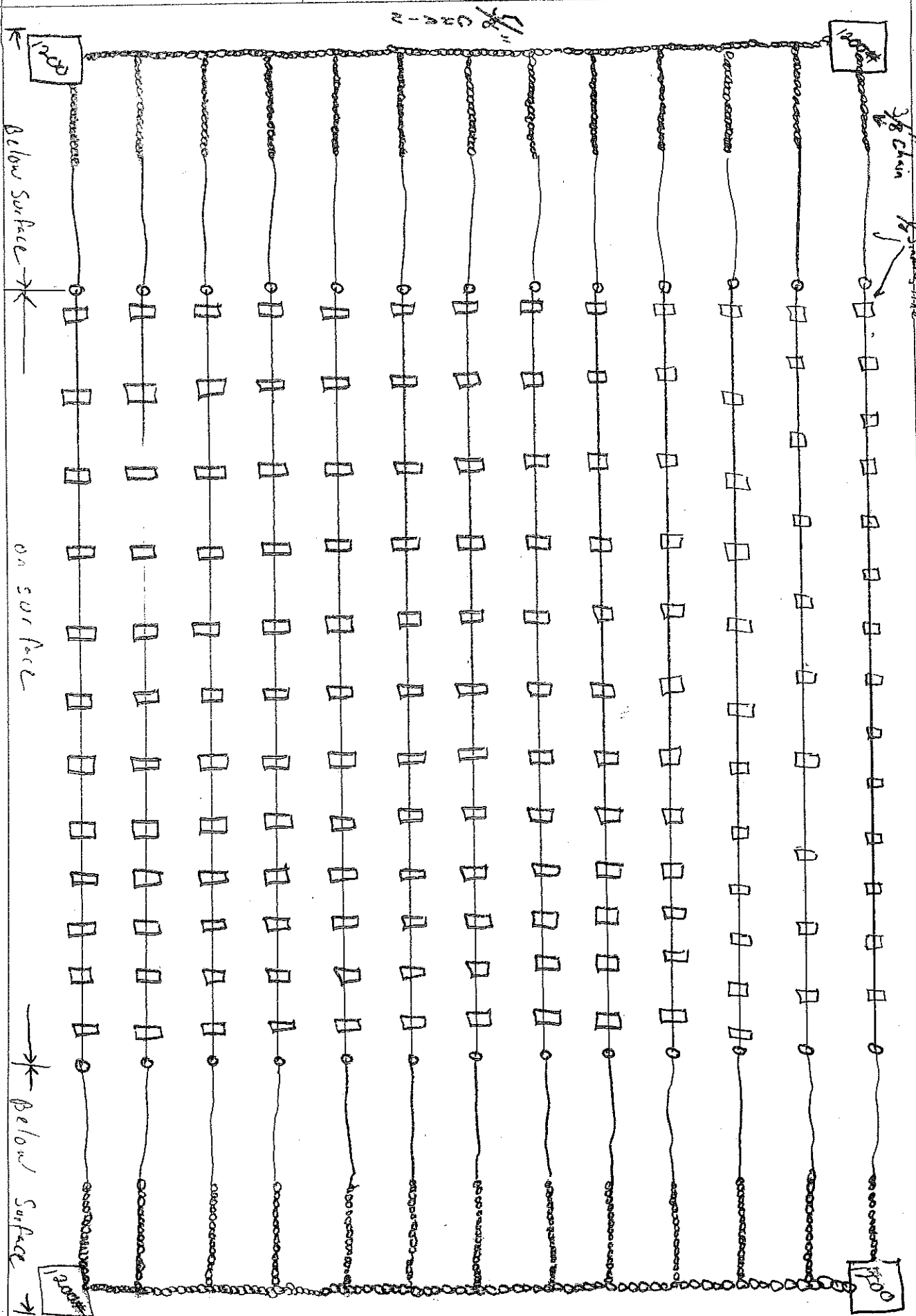

OSTER CAGES

30

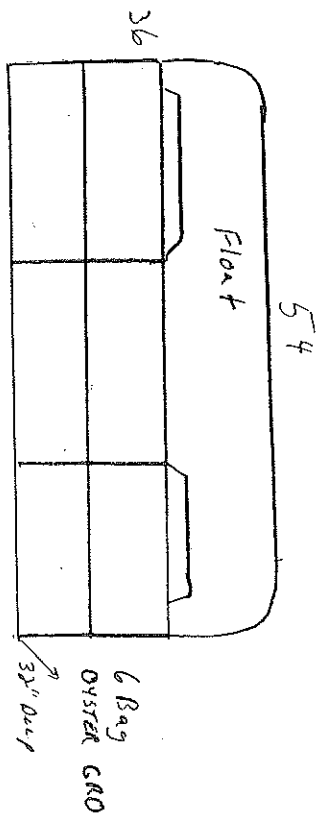

FLOATING OYSTER CAGES
 MAJORITY 6 BAG OYSTER GRO w/ SOME LEAG
 4+ 6 BAG OYSTER RANCHERS
 ALL CAN BE FLIPPED TO "CLEAN"
 POSITION
 ALL WILL BE SUNK IN WINTER

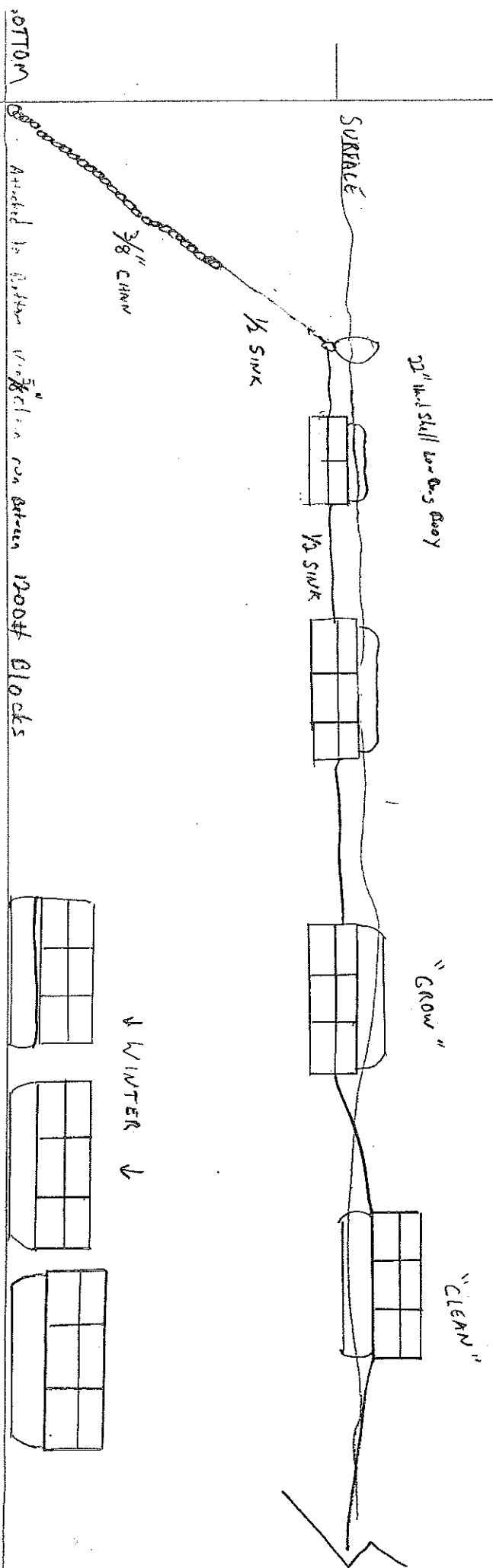

↓ WINTER ↓

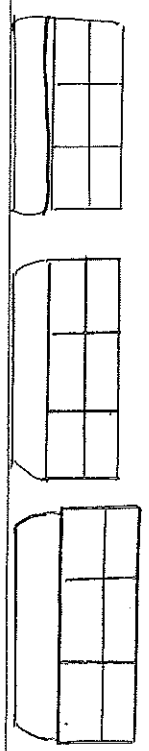

QUAHOG GROWOUT BAGS

QUAHOG GROW OUT BAGS ARE OYSTER BAGS WITH REBAR ATTACHED TO THE INSIDES WITH ELECTRICAL TIES. BAGS ARE ATTACHED IN A STRING AND BUOYED ON EACH END
" No mooring or anchor system is used.

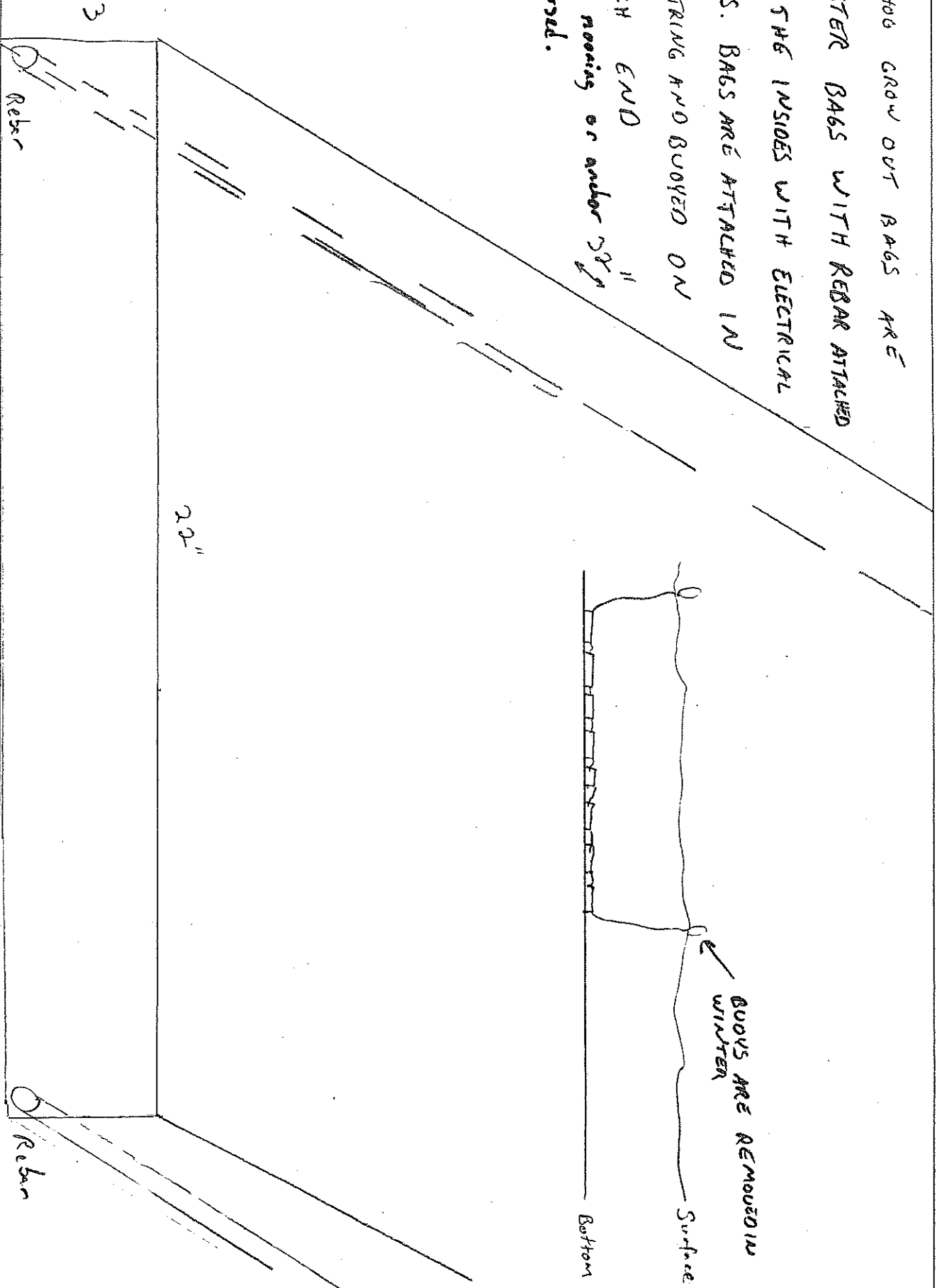

SCALLOP CARS

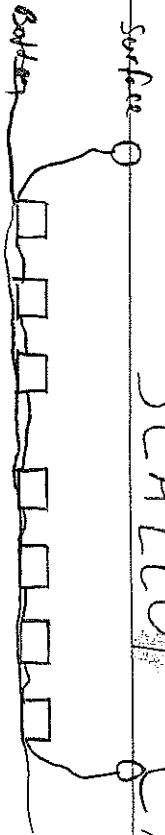

SCALLOP CARS - USING RECYCLED
48" LOBSTER TRAPS. ALL NETTING
AND EXITS REMOVED AND PATCHED.
RUN IN STRINGS. BUOYS REMOVED
DURING WINTER. NO MOORING OR
ANCHOR IS USED.

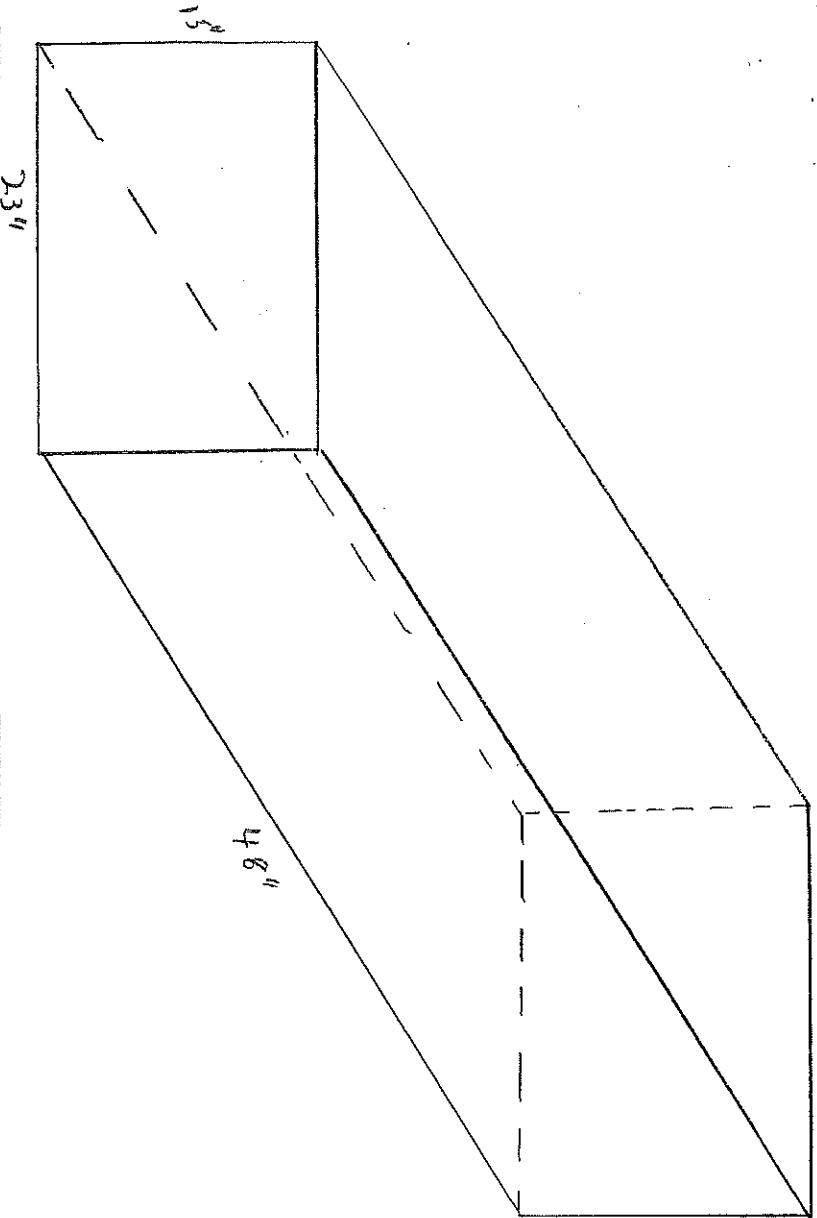

SUMMER
SIDE TOP

WINTER
SIDE TOP

EE

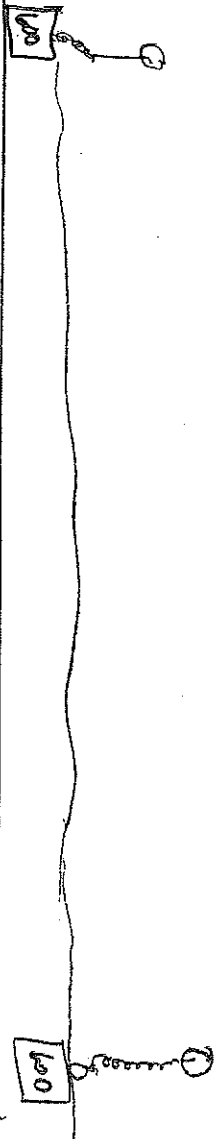
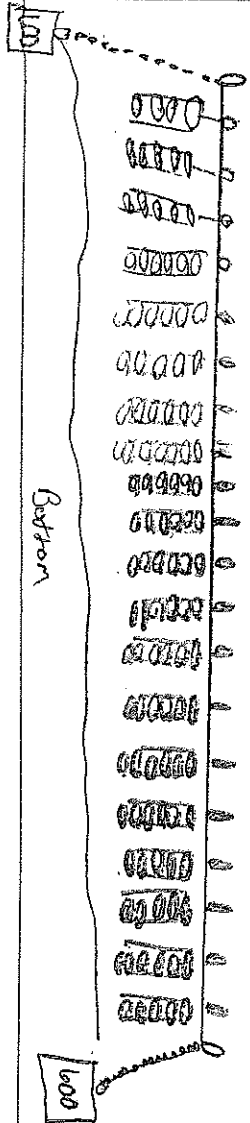

SCALLOP
LANTERN
NETS

MAY 15 - 00115

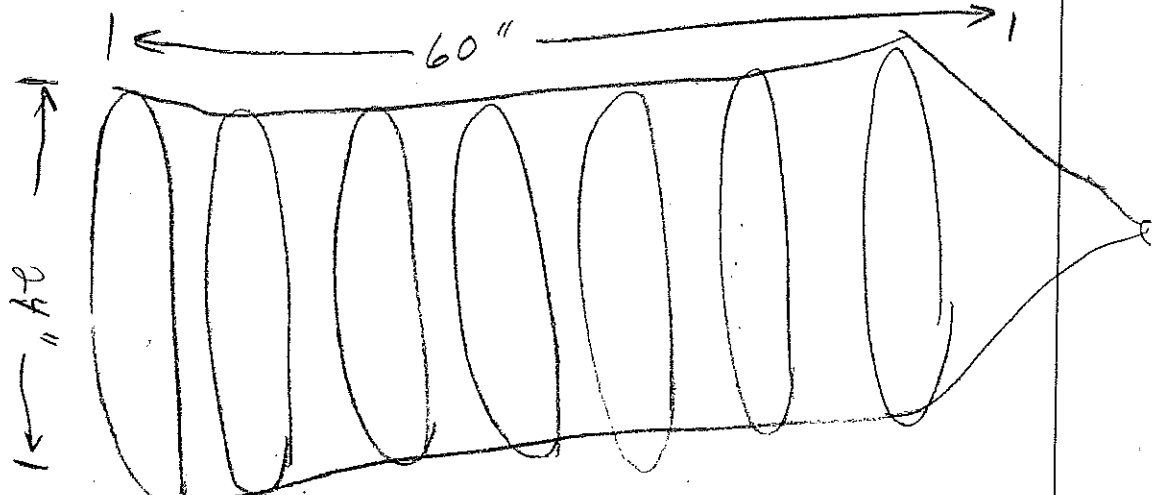

□ = 2"
36" x 18" x 2.5" OYSTER BAG

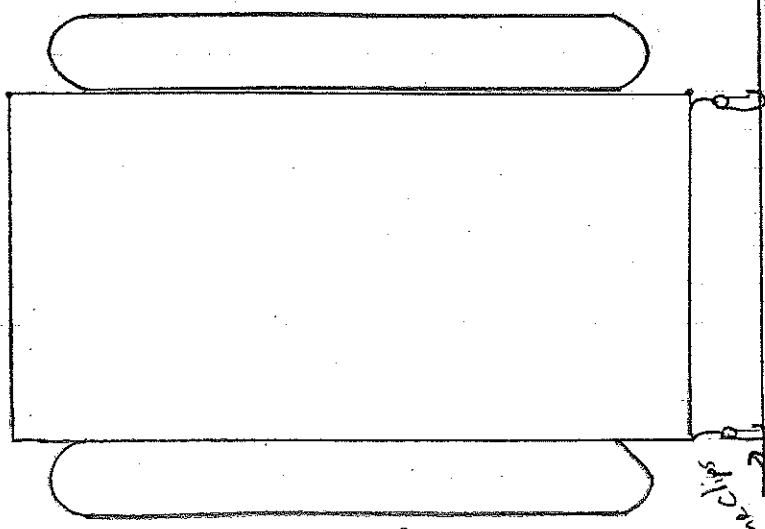

Long Line
Clip

Flow

