

## STANDARD LEASE APPLICATION: NON-DISCHARGE

### 1. APPLICANT CONTACT INFORMATION

|                     |   |   |                  |
|---------------------|---|---|------------------|
| Applicant           | Thomas Henninger  |   |                  |
| Contact Person      | Heidi Henninger   |   |                  |
| Address             | 492 West Elm St   |   |                  |
| City                | Yarmouth  |   |                  |
| State, Zip          | ME 04096  |   |                  |
| County              | Cumberland  |   |                  |
| Telephone           | 207-318-5617  |   |                  |
| Email               | hlhenninger@me.com  |   |                  |
| Type of Application | <input checked="" type="checkbox"/> Draft Application [submitted before scoping session] <span style="margin-left: 100px;"><input type="checkbox"/> Final Application [submitted after scoping session]</span>                          |   |                  |
| Dates               | Pre-Application Meeting: 1/5/22   | Draft Application Submitted: 2/7/22 (revised 3/28/2022) | Scoping Session: |
| Payment Type        | Draft Application: <input type="checkbox"/> Check (included) <input type="checkbox"/> Credit Card<br>Final Application: <input type="checkbox"/> Check (included) <input type="checkbox"/> Credit Card<br><i>(previously submitted)</i> |   |                  |

**Note:** The email address you list here will be the primary means by which we will contact you. Please provide an email address that is checked regularly. If you do not use email, please leave this blank.

### 2. PROPOSED LEASE SITE INFORMATION

| Location of Proposed Lease Site                                 |   |
|---|---|
| Town  | Yarmouth  |
| Waterbody   | Little John Island, Casco Bay   |
| General Description (e.g. south of B Island)                    | Northwest of the eastern end of Little John Island  |
| Lease Information   |   |
| Total acreage requested (100-acre maximum)                      | 6.37 acres  |
| Lease term requested (20-year maximum)                          | 20 year   |
| Type of culture (check all that apply)                          | <input type="checkbox"/> Bottom (no gear)<br><input checked="" type="checkbox"/> Suspended (gear in the water and/or on the bottom) |
| Is any portion of the proposed lease site above mean low water? | <input type="checkbox"/> Yes <input checked="" type="checkbox"/> No   |

**Note:** If you selected yes, you need to complete the steps outlined in the section titled: "19. Landowner/Municipal Permission Requirements".

### 3. GROWING AREA DESIGNATION

Directions: Information for growing area designations can be found here:

<https://www.maine.gov/dmr/shellfish-sanitation-management/closures/index.html>

|                                     |    |
|-------------------------------------|----|
| Growing Area Designation (e.g. WL): | WI |
| Growing Area Section (e.g. "A1"):   | P5 |

**Note:** If you are proposing to grow molluscan shellfish in waters classified as anything other than open/approved, you will need to contact the Bureau of Public Health to discuss your plans at the following email: [DMRPublicHealthDiv@maine.gov](mailto:DMRPublicHealthDiv@maine.gov)

### 4. SPECIES INFORMATION

A. Please complete the table below and add additional rows as needed.

| Name of species to be cultivated<br>(include both common and scientific names): | Name and address of the source of seed stock or juveniles             | Maximum number (or biomass) of organisms you anticipate on the site at any given time |
|---|---|---|
| 1. American Oyster<br><i>Crassostrea virginica</i>                              | Mook Sea Farm 321 ME Rt<br>129, Walpole, ME 04573                     | 1.5 million   |
| 2. American Oyster,<br><i>Crassostrea virginica</i>                             | Muscungus Bay Aquaculture<br>24 Seal Ledge Ln, Bremen, ME<br>04551    | 1.5 million   |
| 3. American Oyster,<br><i>Crassostrea virginica</i>                             | Hoopers Island Oyster Co 837<br>Chesapeake Dr, Cambridge,<br>MD 21613 | 1.5 million   |
| 4. Sea Scallop <i>Placopecton magellanicus</i>                                  | Thomas Henninger 492 West<br>Elm St, Yarmouth, ME 04096               | 1.5 million   |
| 5. Hard Clam, <i>Mercenaria mercenaria</i>                                      | Muscungus Bay Aquaculture<br>24 Seal Ledge Ln, Bremen, ME<br>04551    | 1 million   |

B. Do you intend to possess, transport, or sell whole or roe-on scallops?  Yes  No

If you answered "yes" please contact the Bureau of Public Health to discuss your plans at the following email: [DMRPublicHealthDiv@maine.gov](mailto:DMRPublicHealthDiv@maine.gov)

**Note:** If you are proposing to grow molluscan shellfish, this application also serves as your written operational plan as required in the National Shellfish Sanitation Program (NSSP) Model Ordinance Chapter 2 and must be maintained in your files. If you wish to submit an operational plan separate from this application, please contact: [DMRPublicHealthDiv@maine.gov](mailto:DMRPublicHealthDiv@maine.gov)

## 5. VICINITY MAP

**Note:** Please label as: 'Vicinity Map'.

**Directions:** Using a NOAA Chart or USGS topographic map, show the area within a minimum of one-half mile of the proposed lease site.

The map needs to display the following:

- The waters, shore lands, and lines of mean high and mean low water within the general area of the lease
- An arrow indicating true north
- A scale bar
- The approximate lease boundaries

## 6. BOUNDARY DRAWING

**Note:** Please label as: 'Boundary Drawing'.

**Directions:** Depict the boundaries of the proposed lease site. Provide a drawing with all corners, directions, and distances labeled. Provide coordinates for each corner as follows:

- Coordinate Description  
Provide geographic coordinates for each corner of the lease site in latitude and longitude as accurately as possible (e.g., to the nearest second or fraction of a second). Identify the datum from the map, chart, or GPS unit used to develop these coordinates. The datum will be shown on the map or chart you are using. The Coordinate Description may be provided separately from the Boundary Drawing.

# Thomas Henninger Standard Lease Vicinity Map

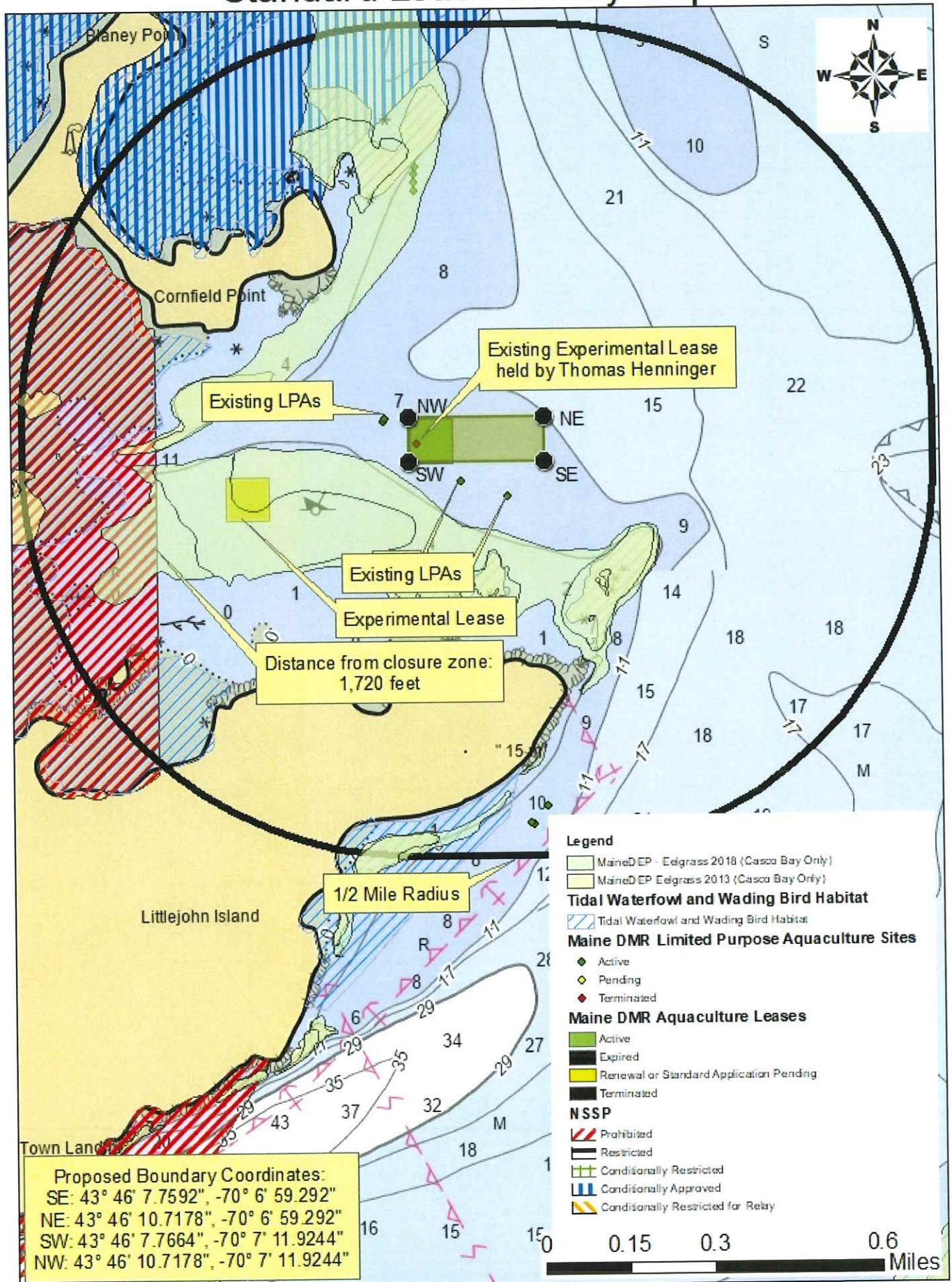

### Little John Standard Lease

Thomas Henninger Standard Lease near Little John Island

Boundary Drawing with tax map overlay.

6.4 Acres

**Legend**

 Thomas Henninger Standard Lease

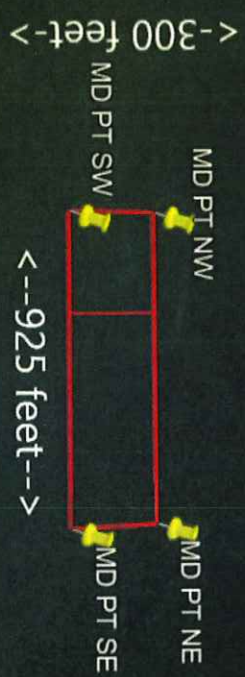

Proposed Boundary Coordinates:

SE: 43° 46' 7.7592", -70° 6' 59.292"

NE: 43° 46' 10.7178", -70° 6' 59.292"

SW: 43° 46' 7.7664", -70° 7' 11.9244"

NW: 43° 46' 10.7178", -70° 7' 11.9244"

1000 ft



Google Earth

© 2021 Google

## 7. SITE DEVELOPMENT

**Directions:** If your operations require the use of cages, nets, ropes, trays, or any object (structure) other than the organism to be grown directly on the bottom or buoys to mark the corners of the lease site, you must submit gear drawings and maximum structure schematics (information below). This section is intended to provide accurate plans depicting the physical structures to be placed in the proposed area. All dimensions need to be labeled with the appropriate units (i.e. 10ft, 10in). If you are proposing a bottom lease (no gear), please skip to question “F. Marking”.

**Note:** You may embed the schematics within the document or attach them to the end of your application. If you attach the schematics, please label them according to the instructions provided below.

### A. Gear Information

**Directions:** Include a drawing of an individual piece of gear for each of the gear type(s) you plan to use. Include units referenced (i.e. 10in, 10ft, etc.).

1. Gear Drawing: Please include the following for each gear type that will hold organisms to be cultured (e.g. polar circles, marine algae longlines, oyster cages) and label as “Gear Drawing”. This view must show the following:
  - Length, width, and height of each gear type.
2. Gear Table: List and describe each individual gear type that you will use in the table below. (e.g. polar circles, marine algae longline, oyster cages, moorings, mooring lines, buoys, etc.).

| Specific Gear Type<br>(e.g. soft mesh bag) | Dimensions<br>(e.g. 16"x20"x2") | Time of year gear will be deployed<br>(e.g. Spring, Winter, etc.) | Maximum amount of this gear type that will be deployed on the site<br>(i.e. 200 cages, 100 lantern nets, etc.) | Species that will be grown using this gear type |
|--|---------------------------------|---|--|---|
| OysterGro cages and floats                 | 41" x 68" x 22"                 | Throughout the year; sunk Nov - April                             | Up to 624 cages  | Eastern Oyster / Scallop / Clam                 |
| OysterGro bags                             | 19" x 35" x 3"                  | Inside cages (6 bags per cage) constant                           | 3744 bags  | Eastern Oyster / Scallop / Clam                 |
| Lantern Nets                               | 30" x 70"                       | Throughout the year   | Up to 624 lantern nets   | Scallop   |
| Bottom cages                               | 36" x 48" x 48"                 | Nov – April, up to 12 cages yr round on bott                      | Up to 624 cages  | Eastern Oyster / Scallop / Clam                 |
| Bird Away Kite                             | 274" fiberglass pole, 22" kite  | Random July - Oct   | 2  |   |

Figure 1: Gear Drawing

# Oyster Gro Cage

(\* not to scale)

## Oyster Gro: Top View

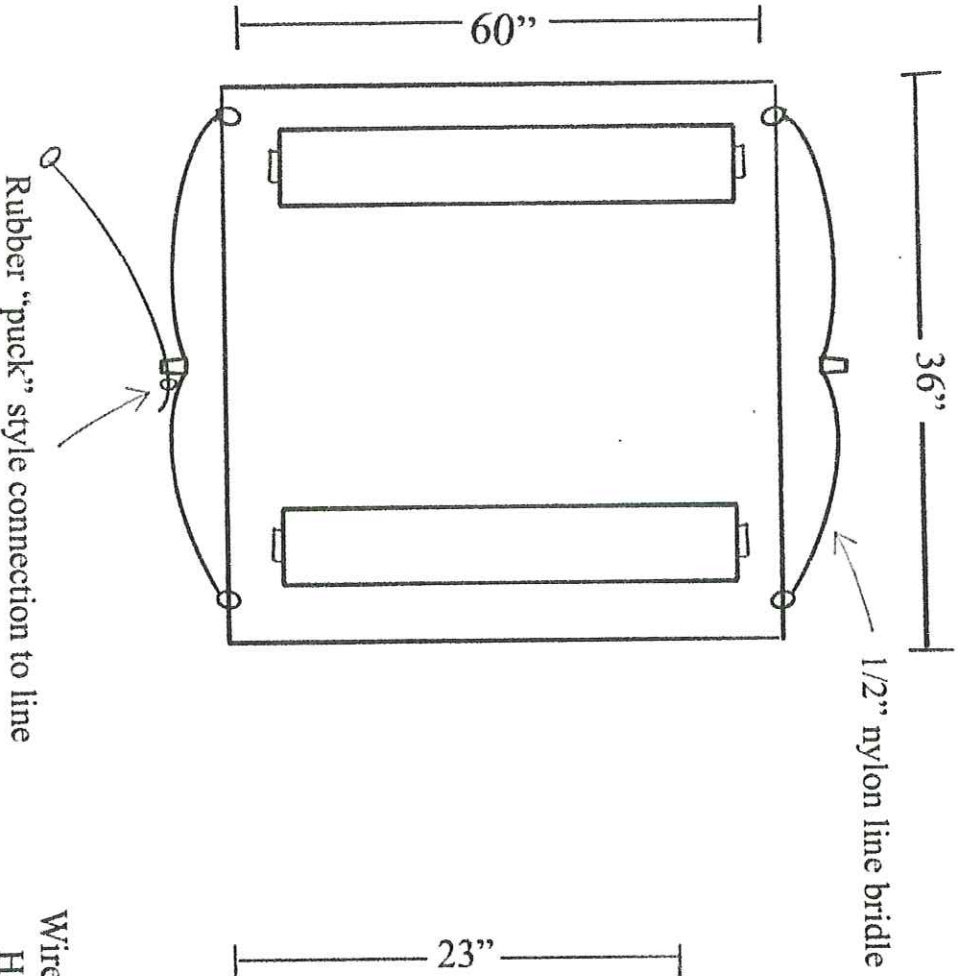

## Oyster Gro: Side View

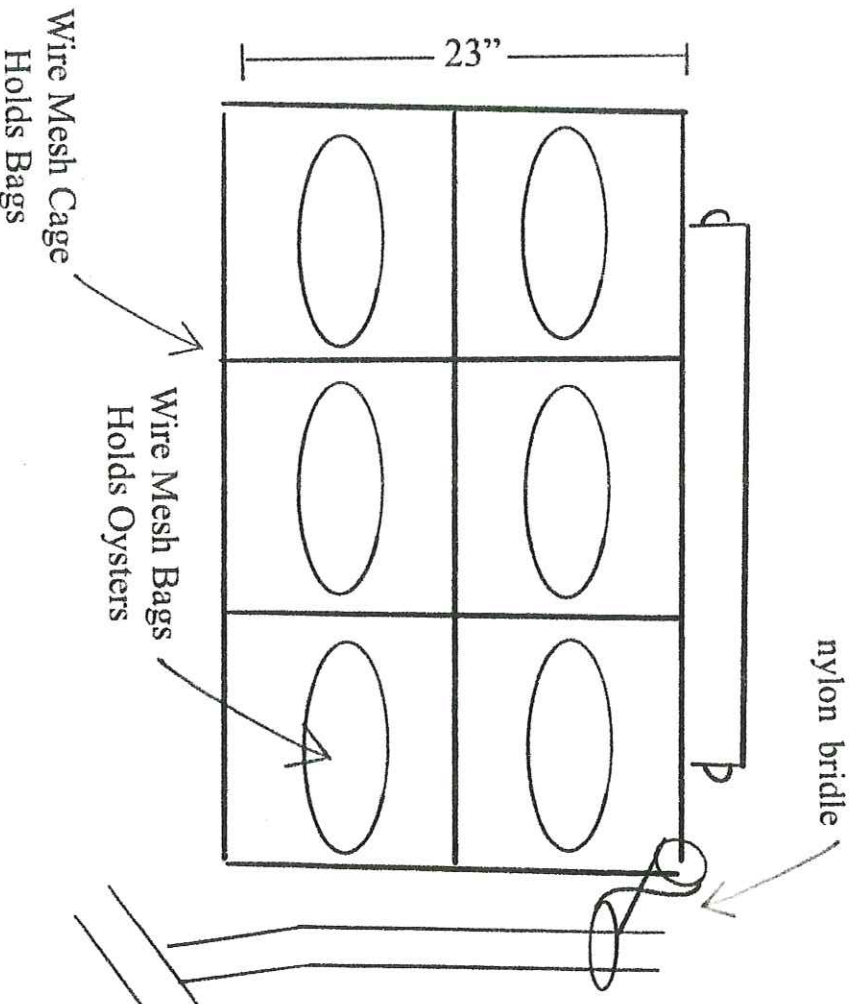

NOT A SCALE



46

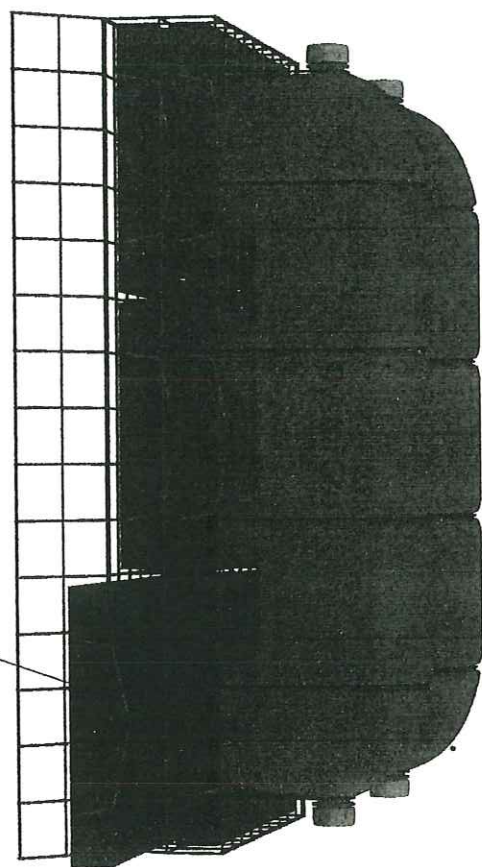
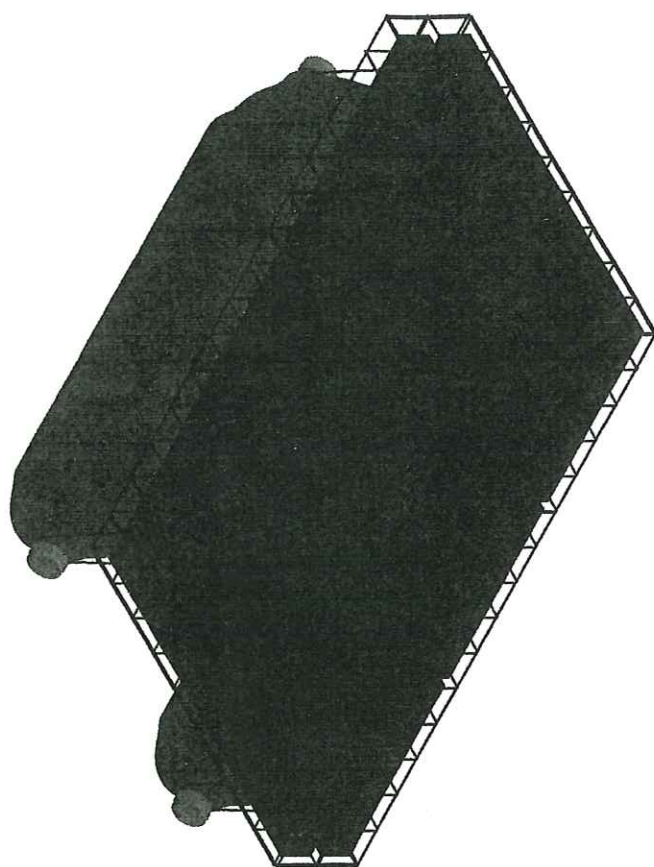

6 OYSTER BAG CAPACITY

\*FLOATS ALSO AVAILABLE IN STEALTH GREY

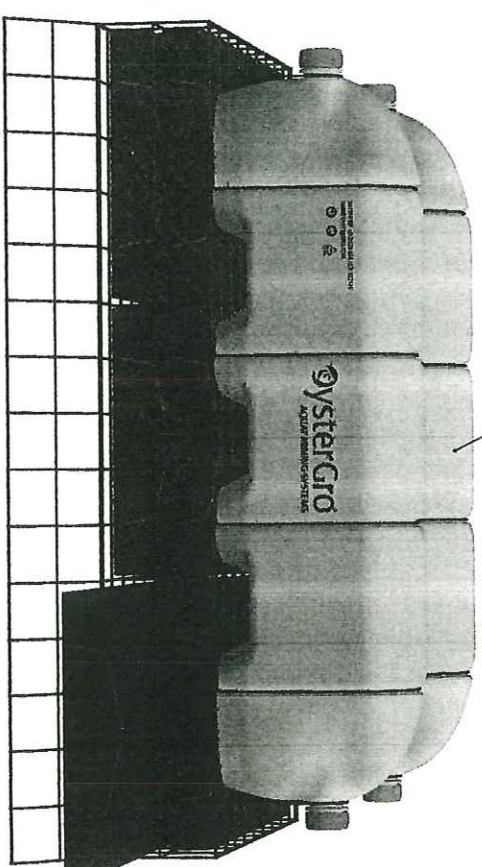
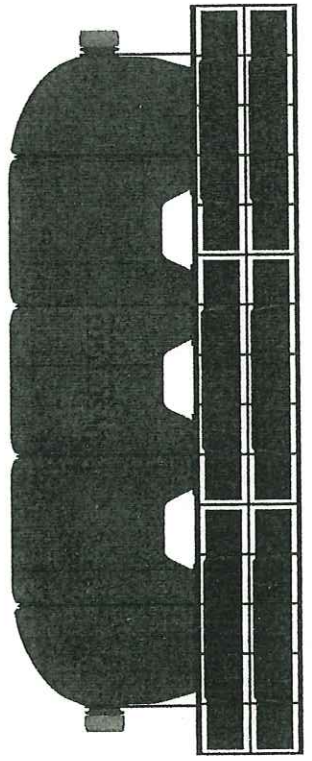

**BOUCTOUCHE BAY INDUSTRIES**

|           |                               |               |                         |             |             |
|-----------|-------------------------------|---------------|-------------------------|-------------|-------------|
| CUSTOMER: | BOUCTOUCHE BAY INDUSTRIES LTD | PROJECT:      | OYSTERGRO CAGE ASSEMBLY | SHEET NO.   | 2 OF 2      |
| UNITS:    | INCHES                        | CUSTOMER P/N: | HF42                    | DRAWN BY:   | J.THERIAULT |
|           |                               | CREATED DATE: | 12/4/2020               | CHECKED BY: | M.GOGUEN    |
|           |                               | APPROVED BY:  |                         |             |             |
|           |                               |               |                         | SCALE:      | NTS         |



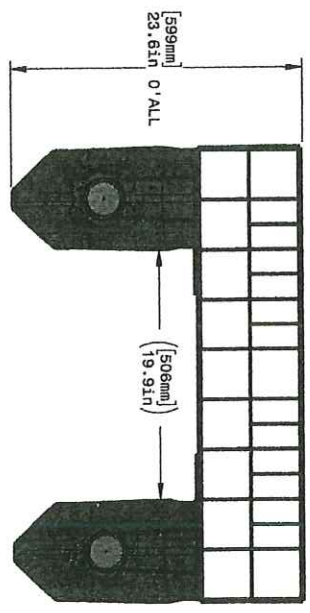
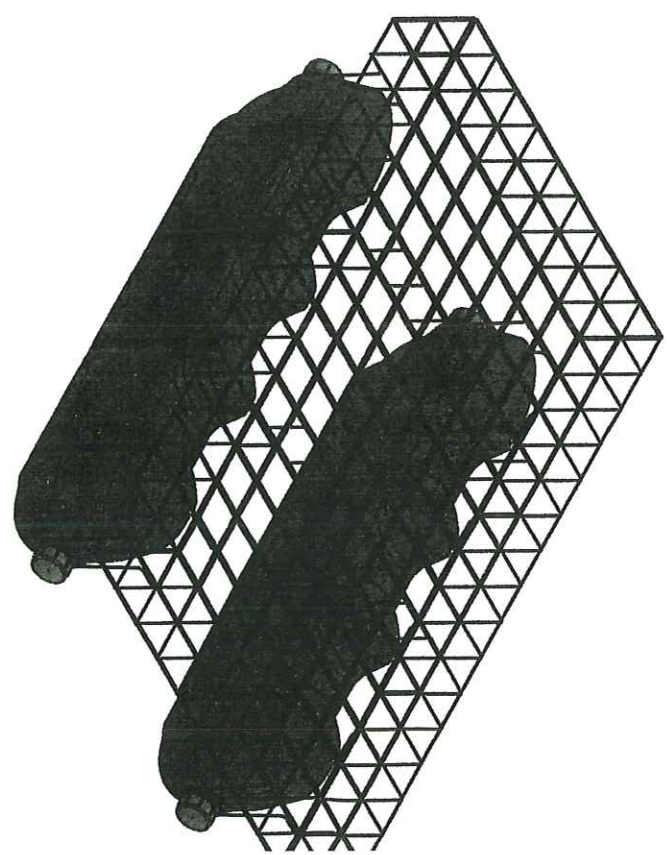
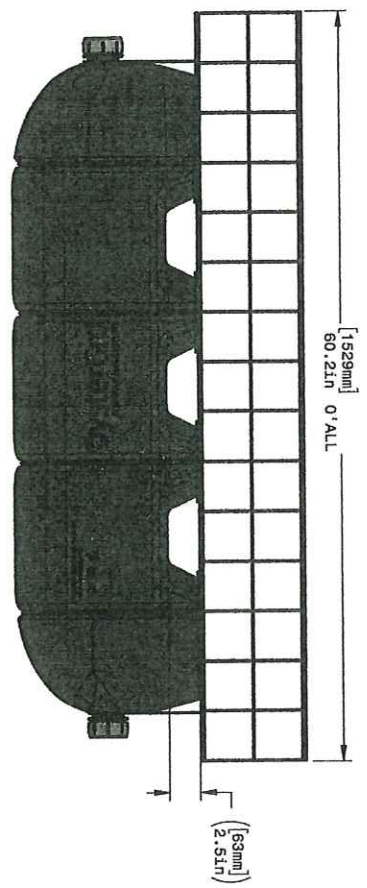
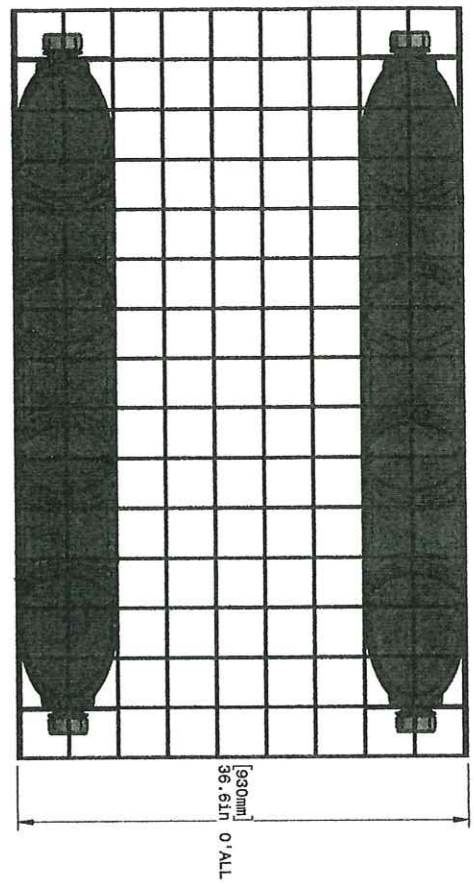

**BOUCTOUCHE BAY INDUSTRIES**

This document may not be used, reproduced or copied without the prior written permission of Bouctouche Bay Industries Ltd.

PO Box 7120, Beauséjour, NB E1S 2J2  
Tel: 506-776-5655 Fax: 506-746-8728  
Email: info@bouctouche.com

|      |            |                        |
|------|------------|------------------------|
| REV. | DATE       | DESCRIPTION            |
| 1    | 01/06/2021 | RELEASED FOR REFERENCE |

CUSTOMER: **BOUCTOUCHE BAY INDUSTRIES LTD**

PROJECT: OYSTERGRO CAGE ASSEMBLY

CUSTOMER P/N: HF42

CREATED DATE: 12/4/2020

DRAWN BY: J.THERIAULT

CHECKED BY: M.GOGUEN

SHEET: 1

SCALE: INCHES

# 6 Bag Bottom Cage Overwintering option

Not to scale

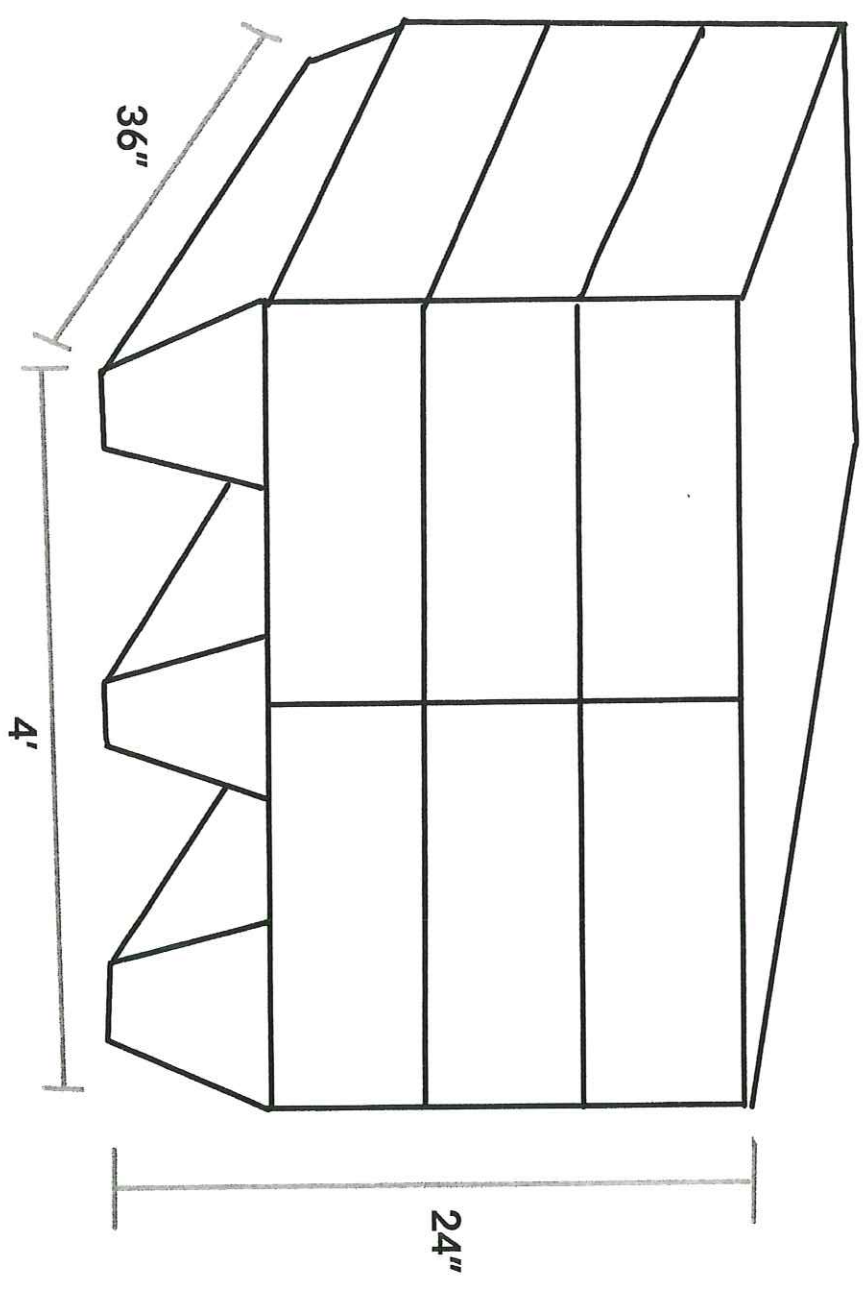

Maine Coast Maine Map:  
Illustrator: Alicia Gaiero

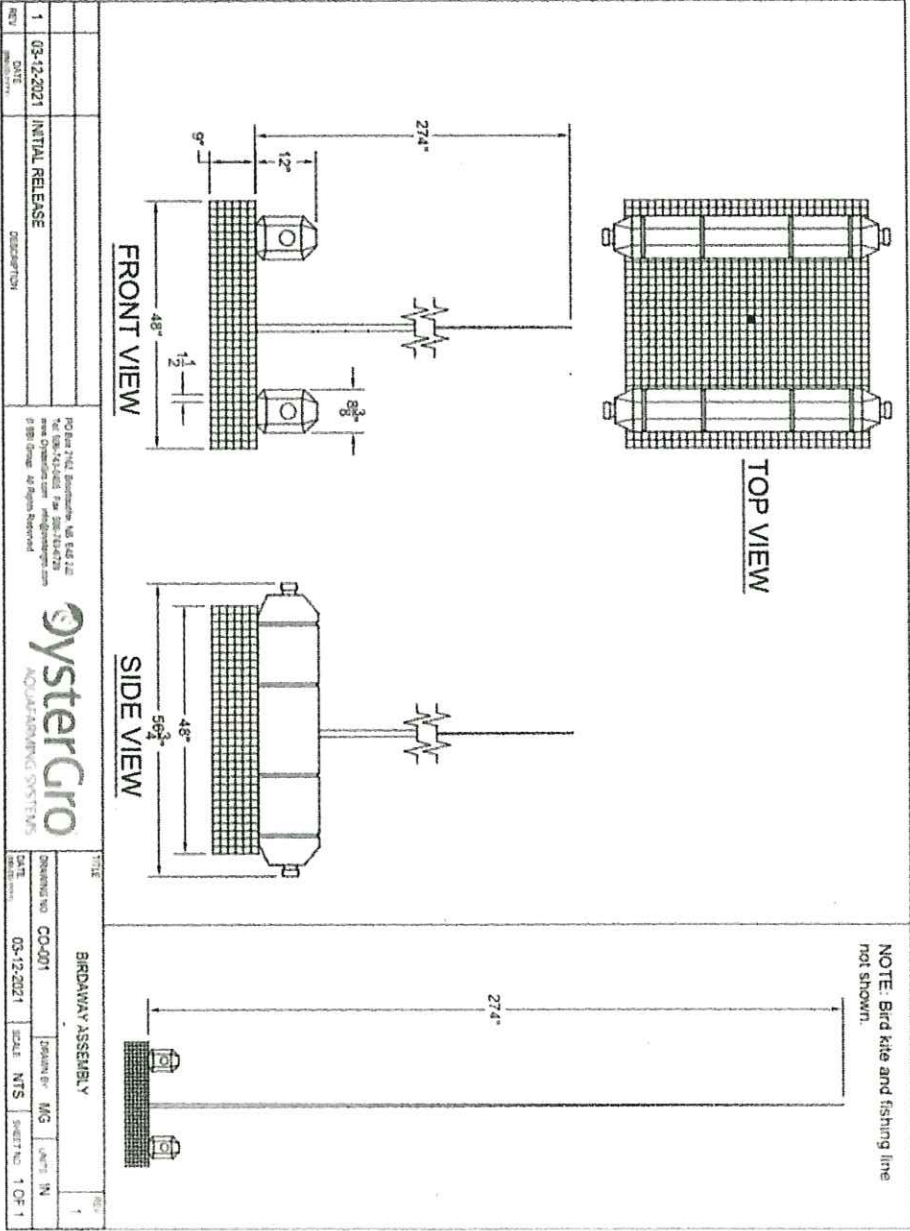

NOTE: Bird kite and fishing line not shown.

|   |  |            |                 |          |  |                  |            |       |     |           |        |       |  |  |  |  |  |                  |  |  |  |  |  |             |  |  |        |  |  |             |  |  |    |  |  |      |  |  |            |  |  |       |  |  |     |  |  |           |  |  |        |  |  |          |  |  |    |  |  |
|---|--|------------|-----------------|----------|--|------------------|------------|-------|-----|-----------|--------|-------|--|--|--|--|--|------------------|--|--|--|--|--|-------------|--|--|--------|--|--|-------------|--|--|----|--|--|------|--|--|------------|--|--|-------|--|--|-----|--|--|-----------|--|--|--------|--|--|----------|--|--|----|--|--|
| 1   |  | 03-12-2021 | INITIAL RELEASE | OPERATOR | PO Box 7142, Sandstone, VA 22472<br>Tel: (804) 424-0400 Fax: (804) 424-0478<br>E-Mail: <a href="mailto:info@oysterpro.com">info@oysterpro.com</a><br>© 2001 Oyster Pro Aquaculture Systems | DATE             | 03-12-2021 | SCALE | NTS | SHEET NO. | 1 OF 1 |       |  |  |  |  |  |                  |  |  |  |  |  |             |  |  |        |  |  |             |  |  |    |  |  |      |  |  |            |  |  |       |  |  |     |  |  |           |  |  |        |  |  |          |  |  |    |  |  |
| <table border="1"> <tr> <td colspan="6">TITLE</td> <td colspan="6">BIRDWAY ASSEMBLY</td> </tr> <tr> <td colspan="3">DRAWING NO.</td> <td colspan="3">CO-001</td> <td colspan="3">DESIGNED BY</td> <td colspan="3">MG</td> </tr> <tr> <td colspan="3">DATE</td> <td colspan="3">03-12-2021</td> <td colspan="3">SCALE</td> <td colspan="3">NTS</td> </tr> <tr> <td colspan="3">SHEET NO.</td> <td colspan="3">1 OF 1</td> <td colspan="3">DRAWN BY</td> <td colspan="3">IN</td> </tr> </table> |  |            |                 |          |  |                  |            |       |     |           |        | TITLE |  |  |  |  |  | BIRDWAY ASSEMBLY |  |  |  |  |  | DRAWING NO. |  |  | CO-001 |  |  | DESIGNED BY |  |  | MG |  |  | DATE |  |  | 03-12-2021 |  |  | SCALE |  |  | NTS |  |  | SHEET NO. |  |  | 1 OF 1 |  |  | DRAWN BY |  |  | IN |  |  |
| TITLE   |  |            |                 |          |  | BIRDWAY ASSEMBLY |            |       |     |           |        |       |  |  |  |  |  |                  |  |  |  |  |  |             |  |  |        |  |  |             |  |  |    |  |  |      |  |  |            |  |  |       |  |  |     |  |  |           |  |  |        |  |  |          |  |  |    |  |  |
| DRAWING NO.   |  |            | CO-001          |          |  | DESIGNED BY      |            |       | MG  |           |        |       |  |  |  |  |  |                  |  |  |  |  |  |             |  |  |        |  |  |             |  |  |    |  |  |      |  |  |            |  |  |       |  |  |     |  |  |           |  |  |        |  |  |          |  |  |    |  |  |
| DATE  |  |            | 03-12-2021      |          |  | SCALE            |            |       | NTS |           |        |       |  |  |  |  |  |                  |  |  |  |  |  |             |  |  |        |  |  |             |  |  |    |  |  |      |  |  |            |  |  |       |  |  |     |  |  |           |  |  |        |  |  |          |  |  |    |  |  |
| SHEET NO.   |  |            | 1 OF 1          |          |  | DRAWN BY         |            |       | IN  |           |        |       |  |  |  |  |  |                  |  |  |  |  |  |             |  |  |        |  |  |             |  |  |    |  |  |      |  |  |            |  |  |       |  |  |     |  |  |           |  |  |        |  |  |          |  |  |    |  |  |

# Utility Mooring Cross-Section View

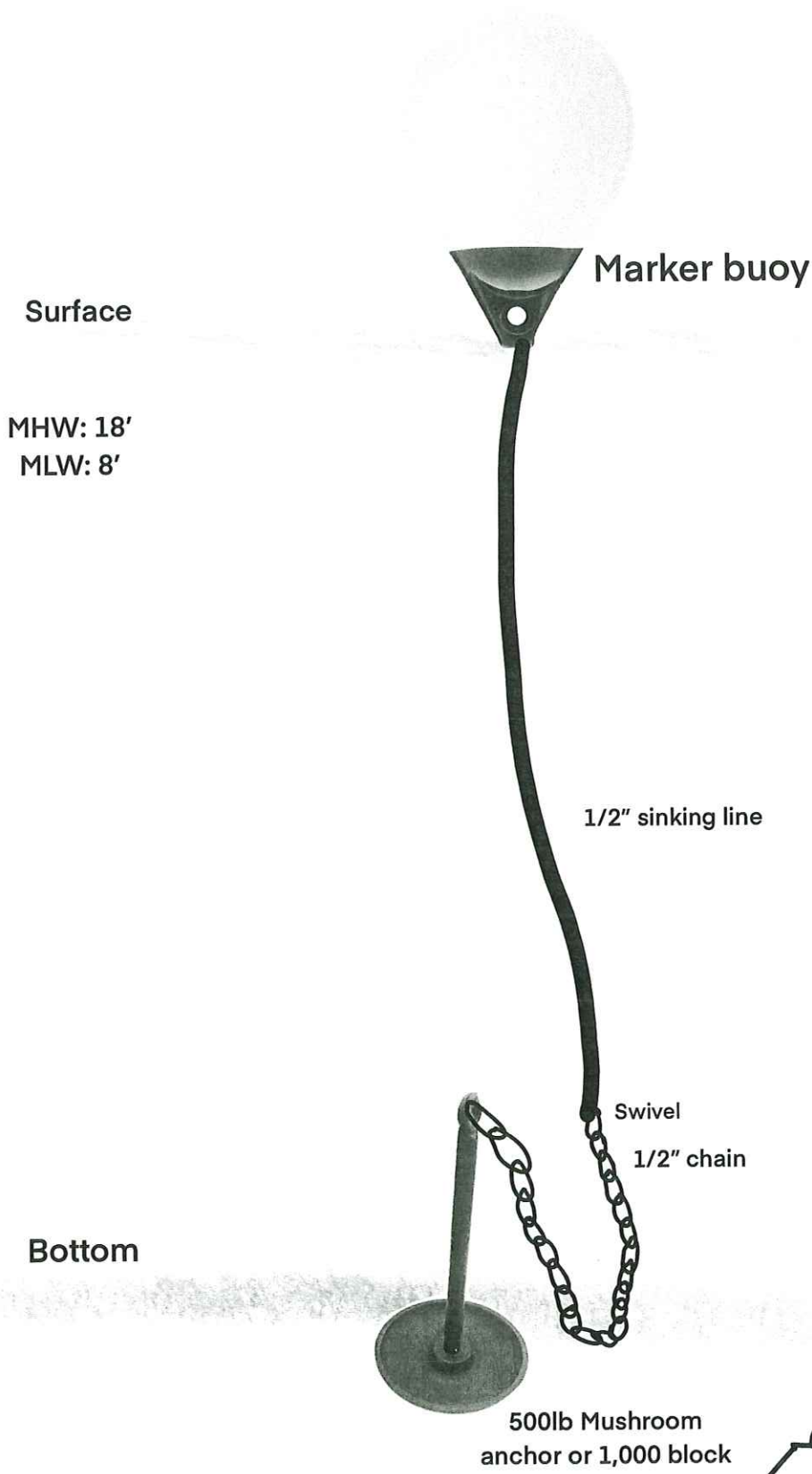

\*Not to scale

4F

# Marker Buoy Cross-Section View

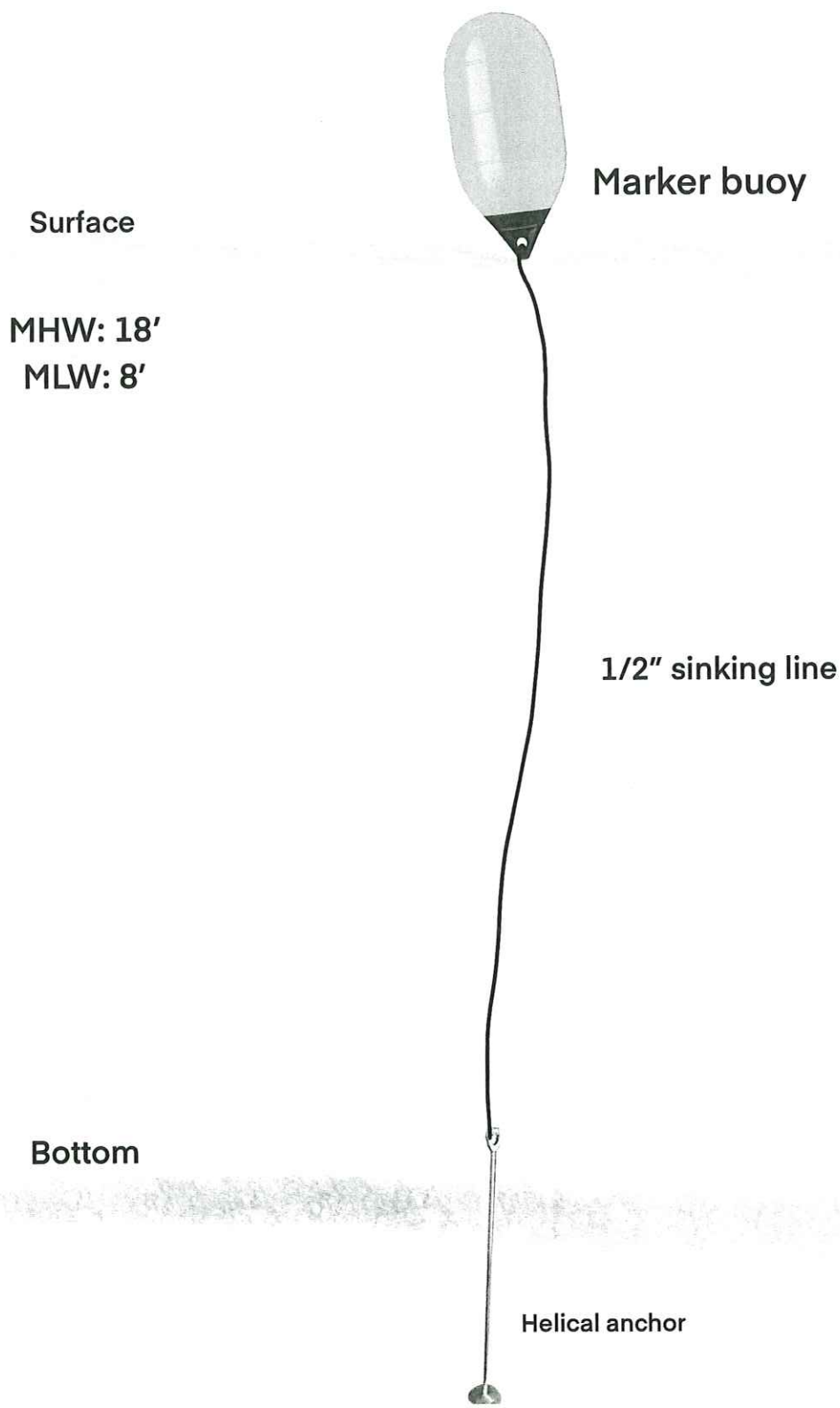

# Marker Buoy Overhead View

MHW: 18'  
MLW: 8'



# Lantern Net Line

**\*Not to scale**

Overhead View

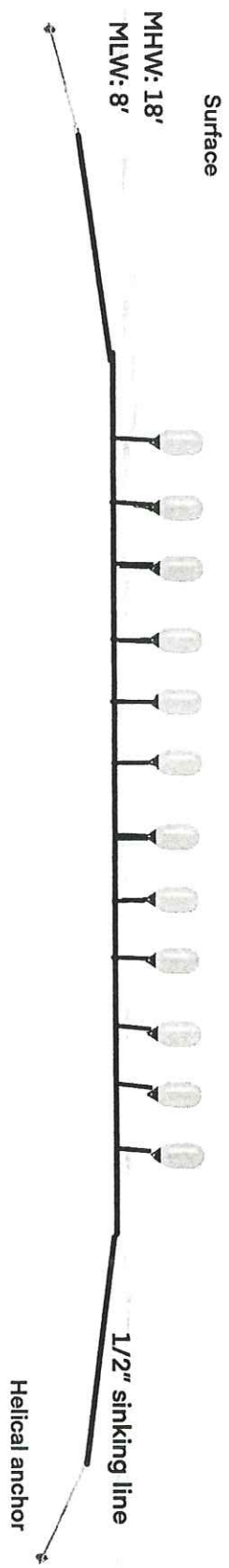

Cross section view

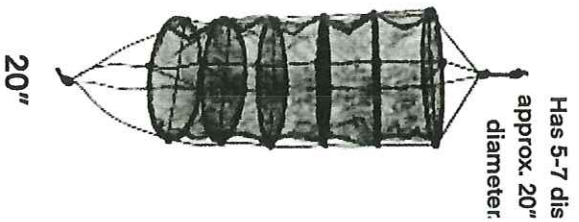
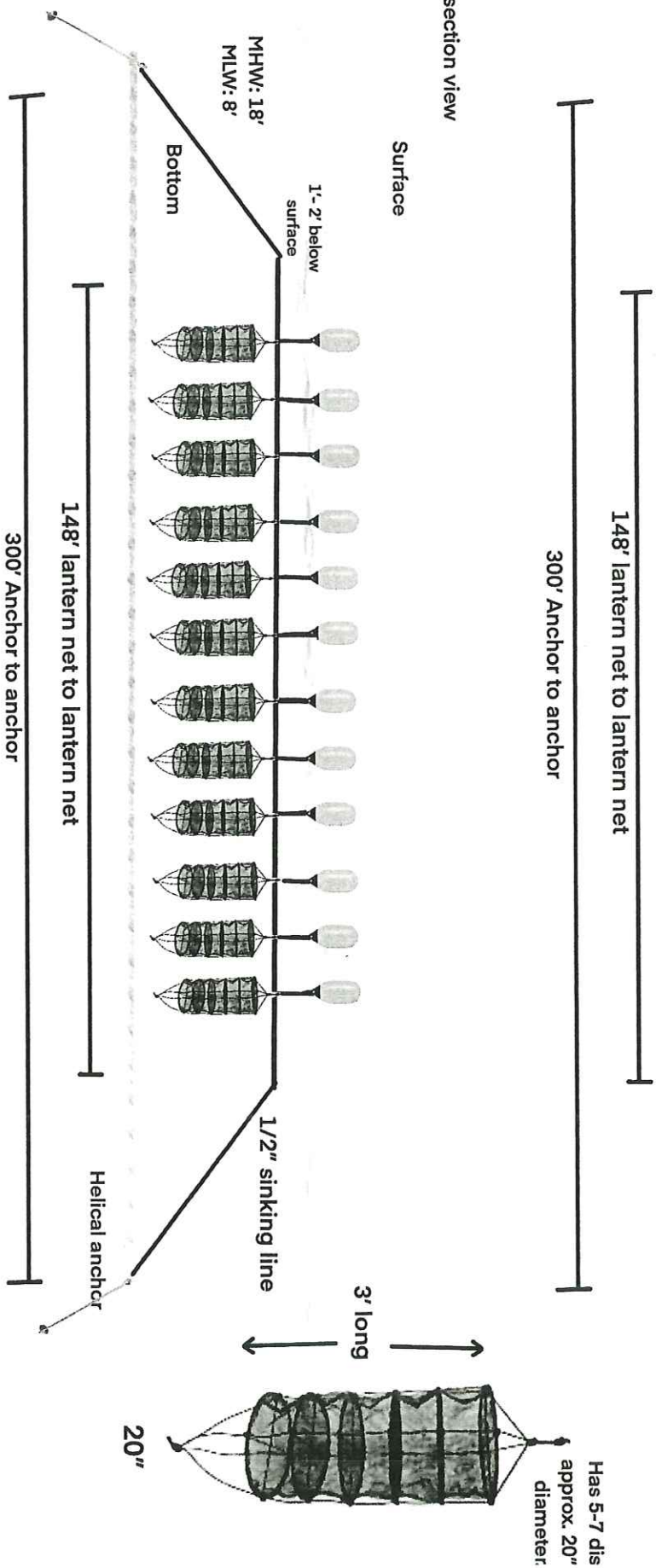

**B. Maximum Structure and Mooring System Schematic**

**Directions:** Include drawings of your maximum gear layout. Include units referenced (i.e. 10in, 10ft, etc.).

1. Overhead View. Please include the following and label as “Overhead View”:
  - Maximum layout of gear, including moorings.
  - Length and width of project.
  - Approximate spacing between gear.
  - Lease boundaries and the location of proposed corner markers and any additional gear markers that would be present.
  
2. Cross-Section View. Please include the following and label as “Cross-Section View”:
  - The sea bottom.
  - Profile of gear in cross-section as it will be deployed.
  - Label gear with dimensions and materials.
  - Show mooring gear with mooring type, scope, hardware, and line type and size.
  - Depth of gear in relation to the water’s surface at mean low water and mean high water (if applicable).

**Note:** Please include an additional Cross Section View, depicting the elements listed above, if there will be seasonal changes to gear layout (i.e. over wintering).

**C. On-Site Support Structures**

|   |
|---|
| 1. Describe structures such as barges, sheds, etc., to be located on-site. Provide a schematic and indicate the dimensions, including height above sea level, materials, etc.   |
| 16’x49’ floating work platform (wood with plastic floats) may be on site; an additional 16’x24’ float may be added for wet storage (wood, wire mesh baskets, plastic floats). If the work float moves off site, the work platform in overhead drawing) will be replaced by 6 strings of 12 cages, adding 72 cages (which explains the discrepancy between gear table maximum of 624 cages but overhead drawing showing 552 cages) |
| 2. Describe the storage and use of oil, gasoline, or other hazardous materials on site. If petroleum products are to be stored on site, provide a spill prevention plan.  |
| none  |



# Thomas Henninger Standard Lease Overhead View

MHW: 18'

MLW: 8'

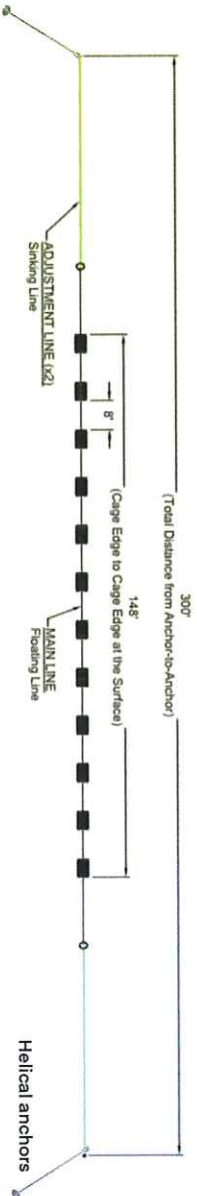
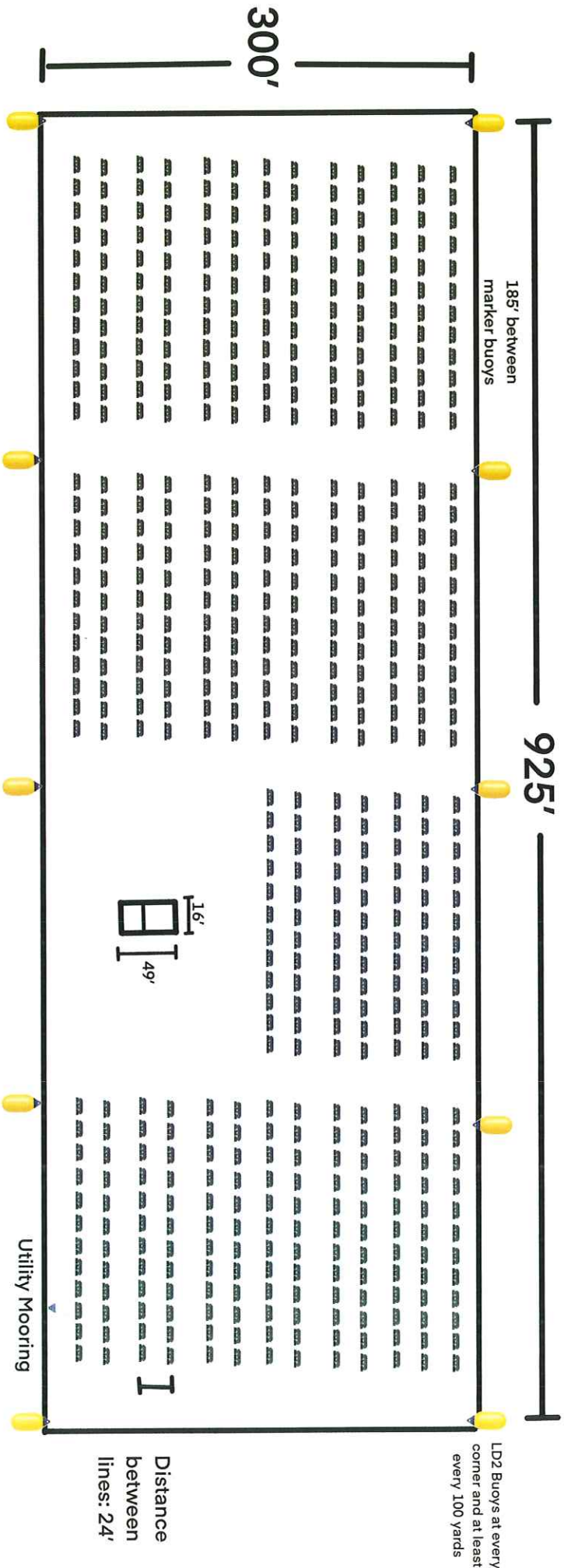

Represents surface cage, bottom cage, lantern net or bird away device

**\* Not to scale**

# 12 Cage Line

\*Not to scale

## Overhead view

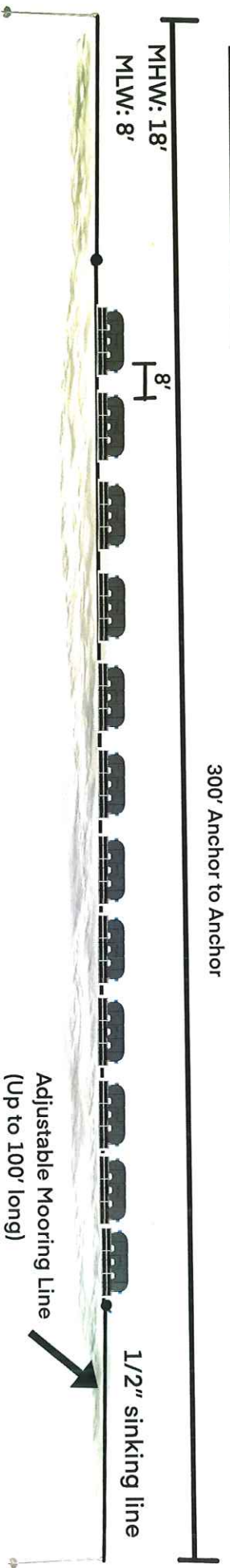

## Cross-Section View

On the surface: Season April-November (up to year round)

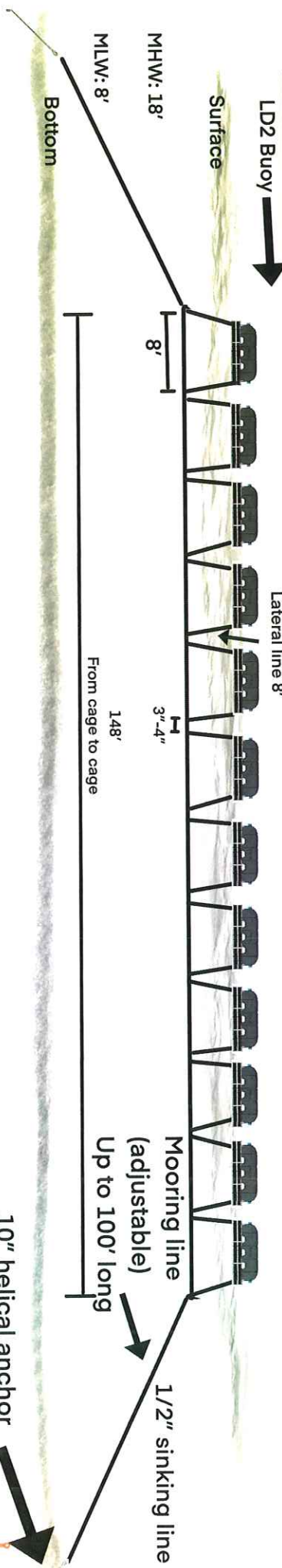

6 Bag Oystergro Cage

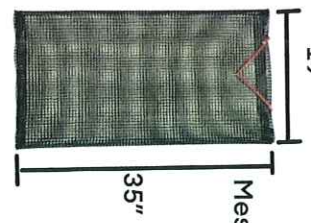
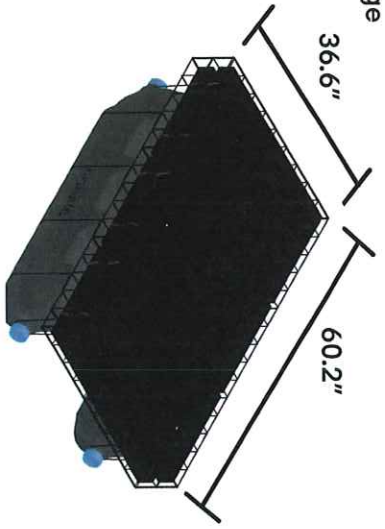
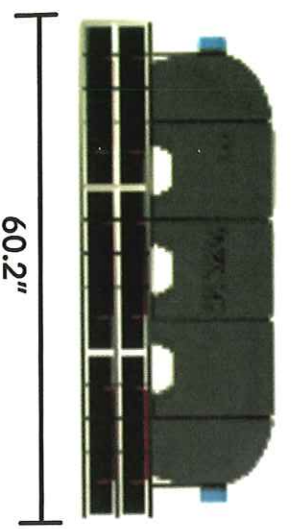

Mesh bag - Max 6 per Cage

- 10" helical anchor
- OR 150 lb Pyramid anchor
- OR 200 lb Mushroom anchor

# Lantern Net Line

**\*Not to scale**

Overhead View

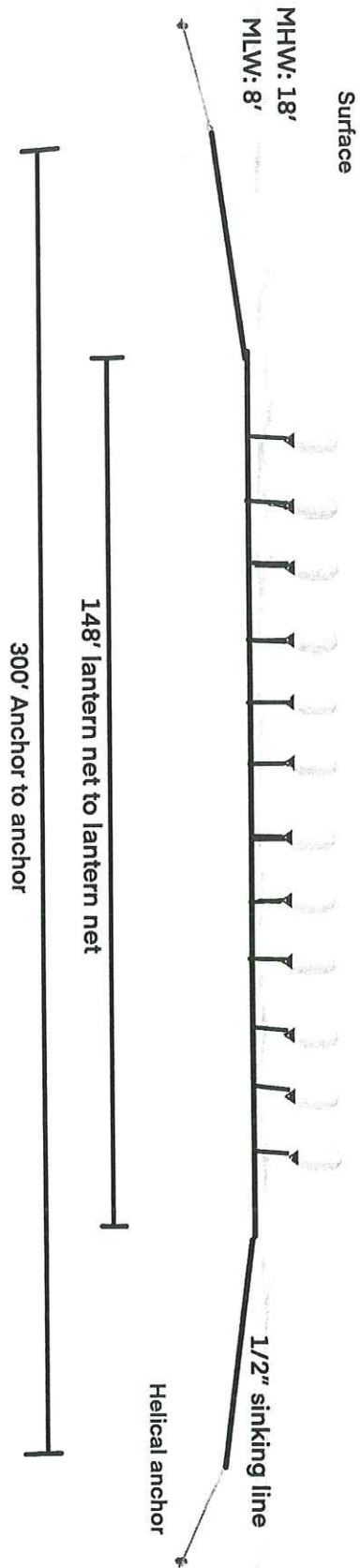

Cross section view

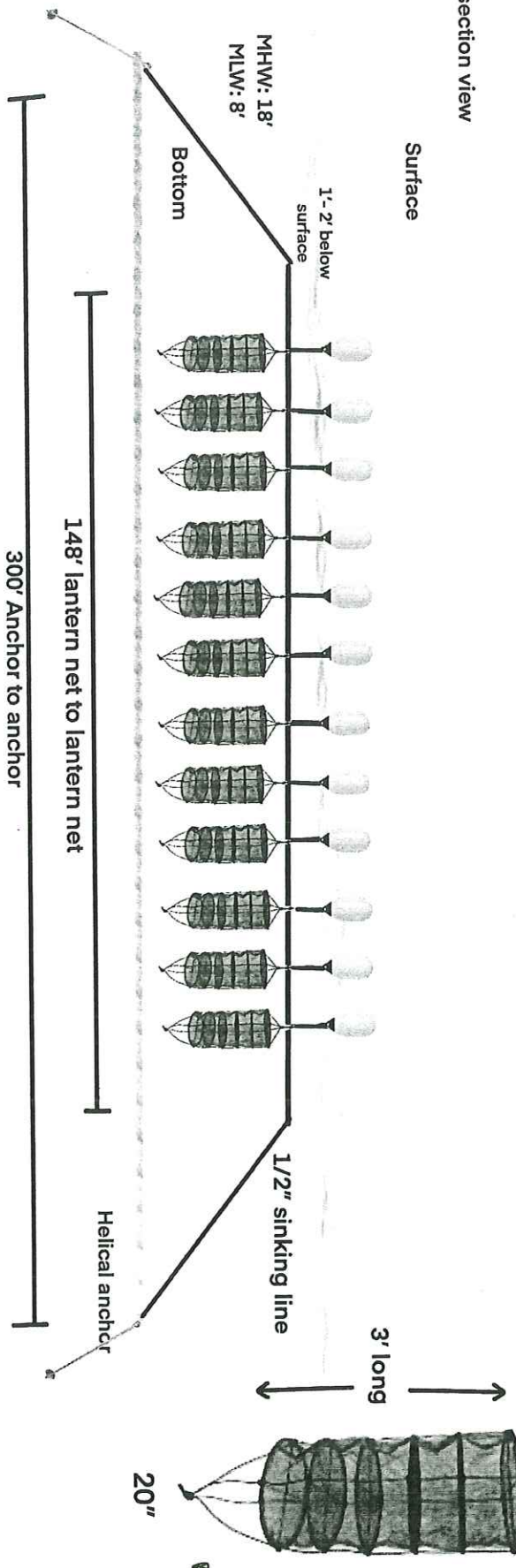

# 6 Bag Bottom Cages

## Overwintering Cross-Section View

November - April

**\*Not to Scale**

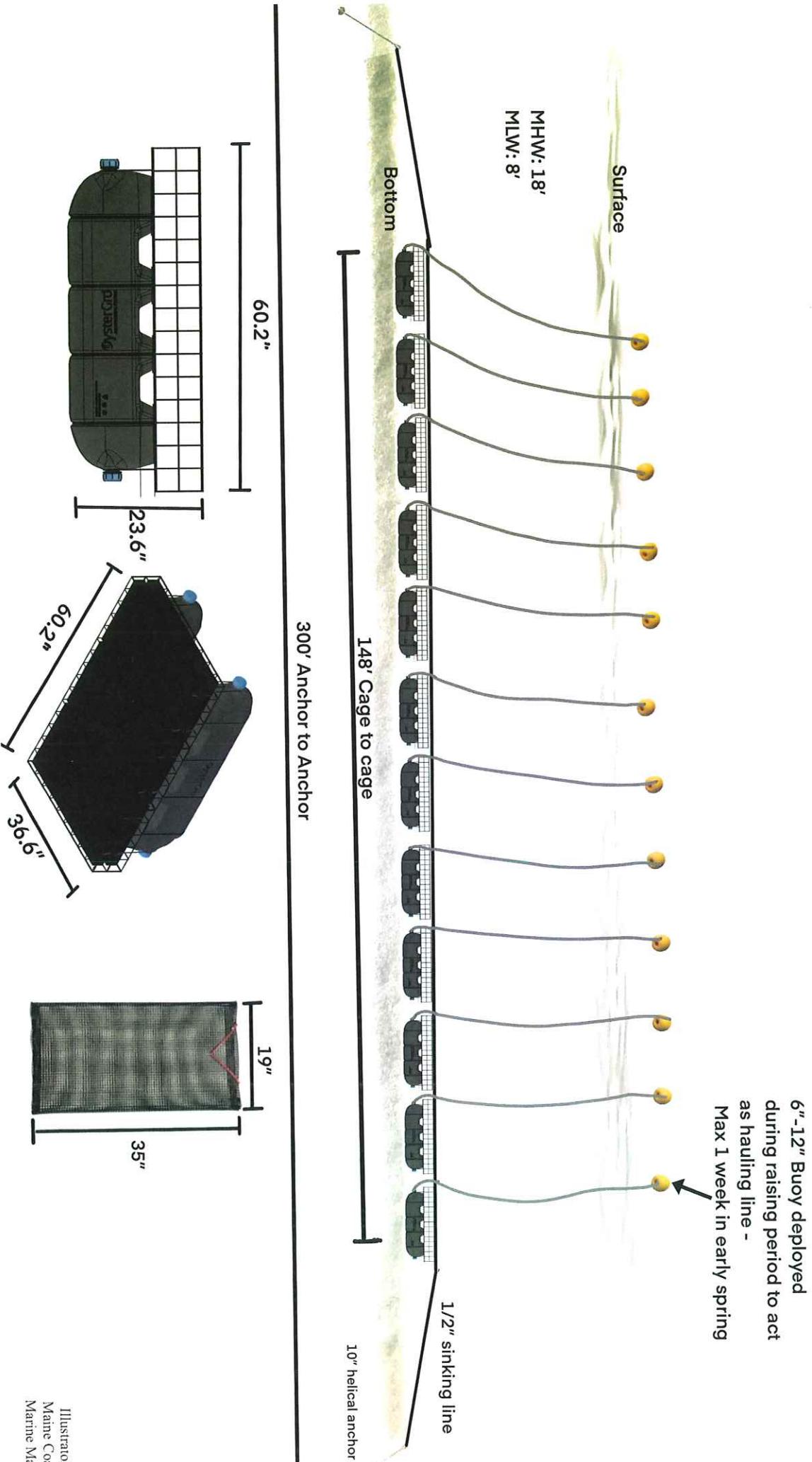

# Floating Work Space Overhead view

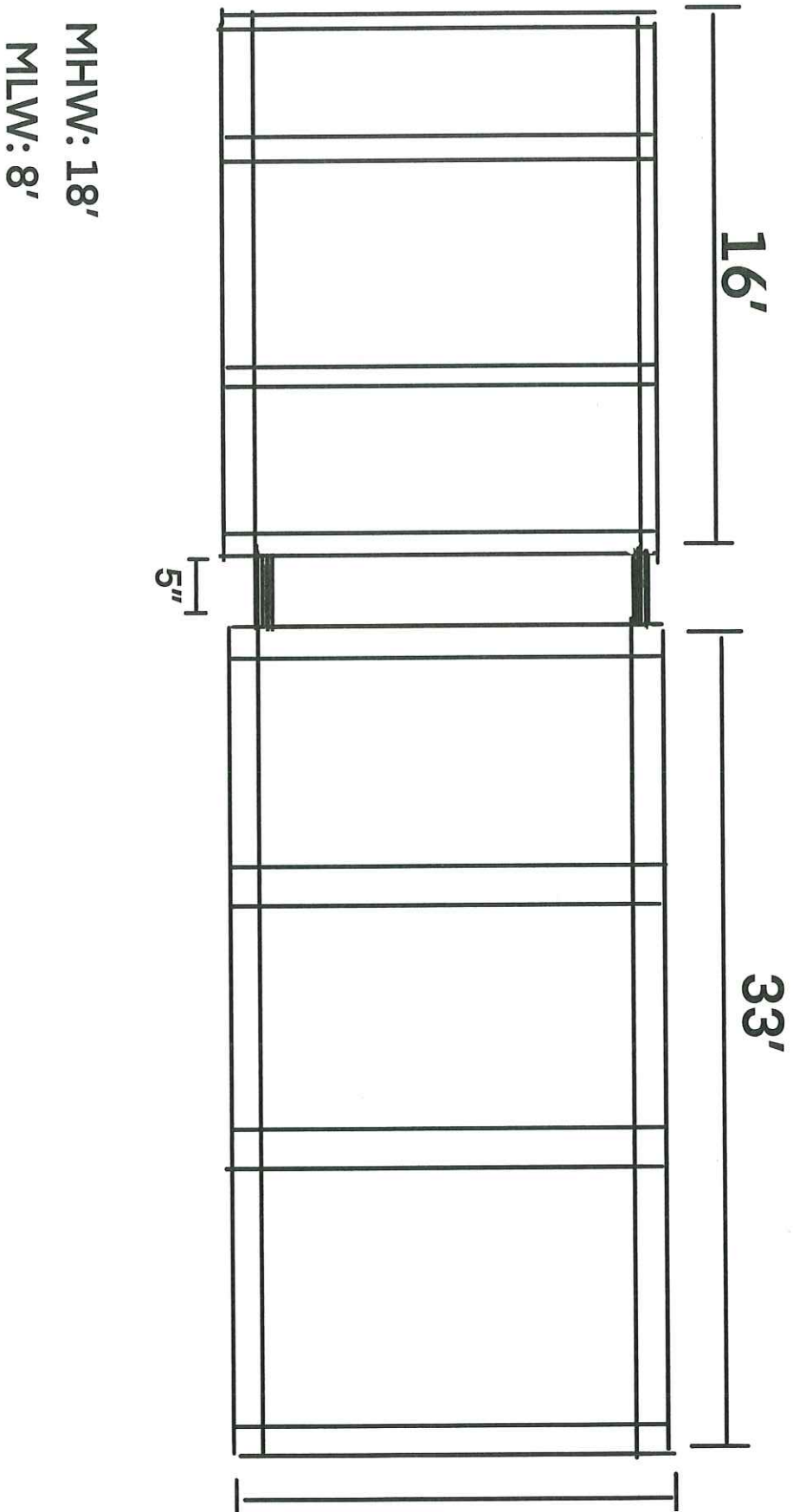

MHW: 18'

MLW: 8'

# Floating Work Space Cross-Section View

\*Not to scale  
Maine Coast Maine  
Illustrator: Alicia Gai

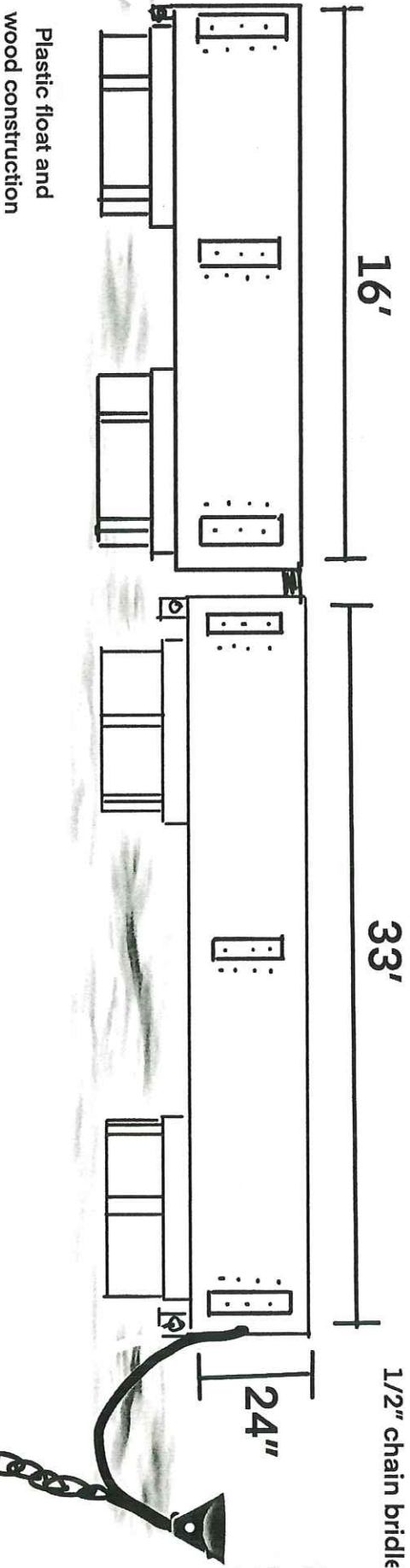

View of bridle

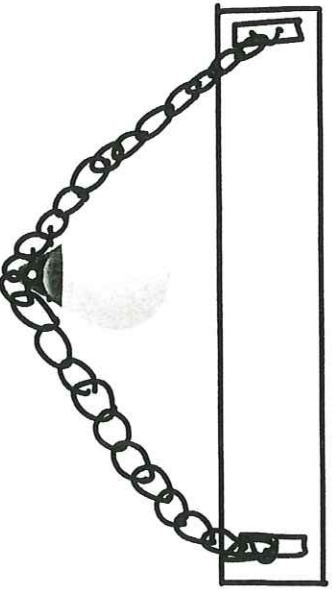

Bottom

4,000 lb mooring block

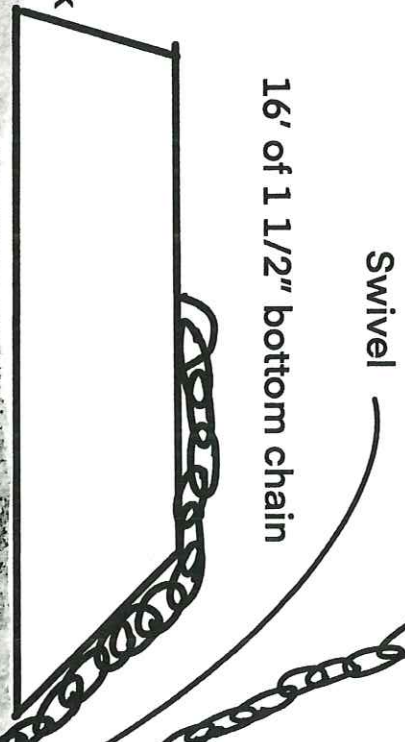

HENNINGER WET STORAGE FLOAT  
NOT TO SCALE

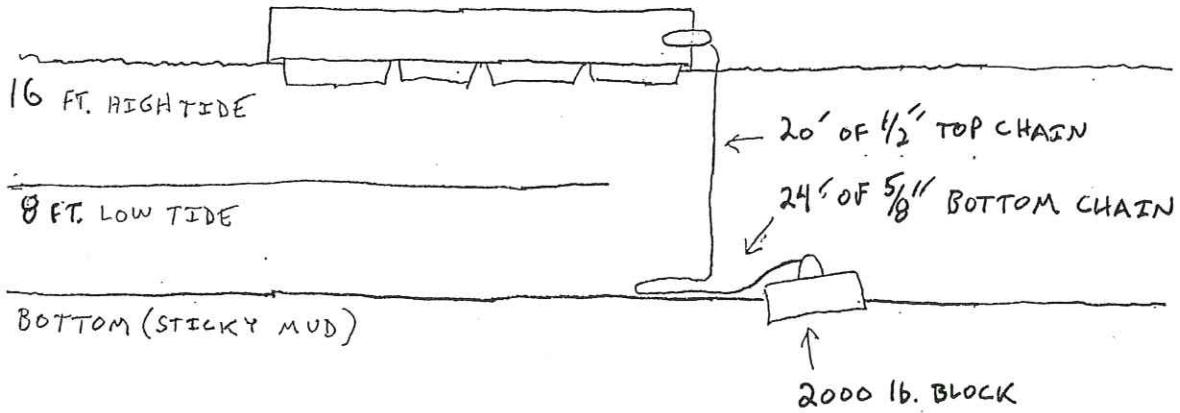

HENNINGER WET STORAGE FLOAT

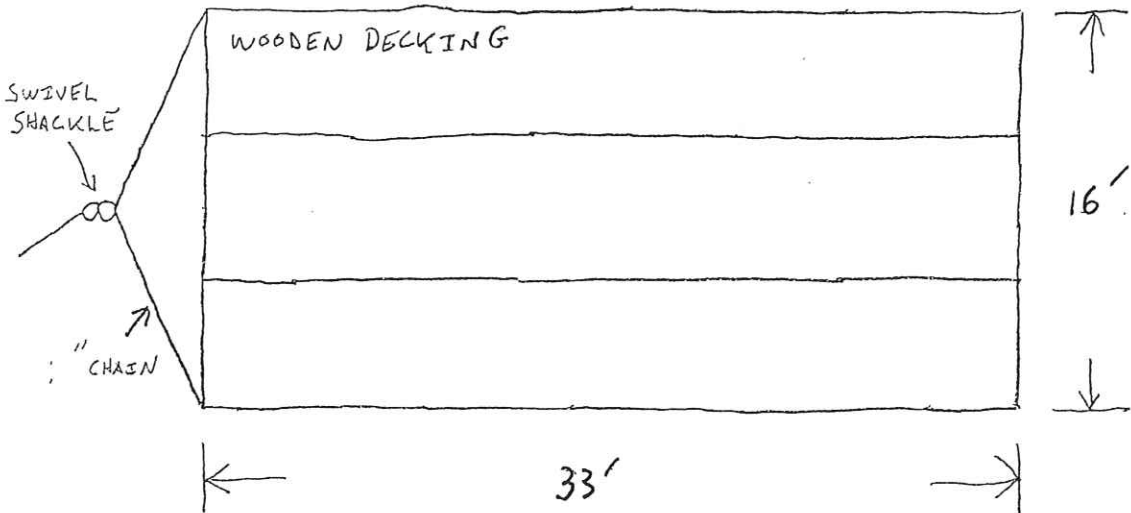

# HENNINGER WET STORAGE FLOAT

NOT TO SCALE

FLOAT FROM ABOVE

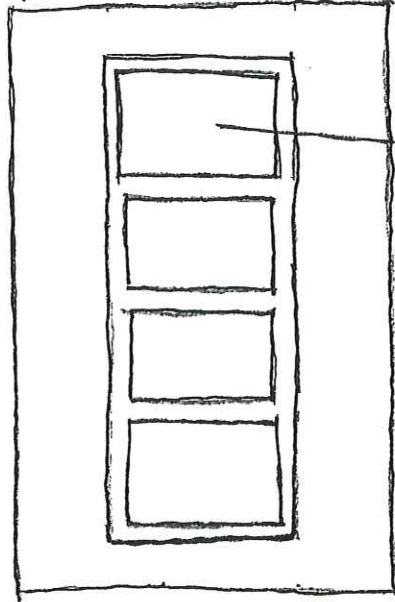

4' DEEP LOBSTER WIRE BASKETS FIT INTO FLOAT

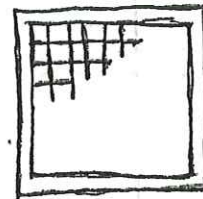
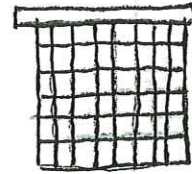

SIDE VIEW

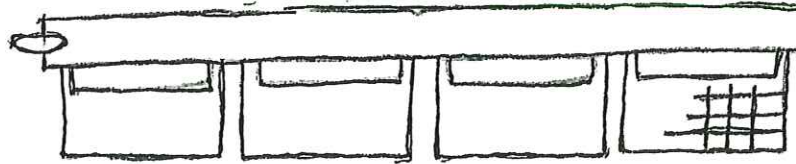



**D. Gear Color**

|  |
|--|
| Provide the color of the gear and structures proposed to be used at the lease site.  |
| OysterGro floats are grey or black. Cages are black wire. Perimeter buoys are yellow |

**E. Equipment Layout**

Provide schematic or photographic renderings of the generalized layout of the equipment as depicted from two vantage points on the water. Provide the locations of the two vantage points.

**F. Marking**

|   |
|---|
| Will you be able to mark your site in accordance with DMR regulations, Chapter 2.80? In part, this requires marker buoys which clearly display the lease ID and the words SEA FARM to be located at each corner of the lease.<br><input checked="" type="checkbox"/> Yes <input type="checkbox"/> No<br>If you answered no, explain why and suggest alternate markings. |
|   |

**Note:** If a lease is granted, you will also be required to mark the site in accordance with appropriate US Coast Guard Regulations. If you have questions about US Coast Guard Regulations contact: 1<sup>st</sup> Coast Guard District, Aids to Navigation Office ((617)-223-3293).

E (Equipment Lay out)

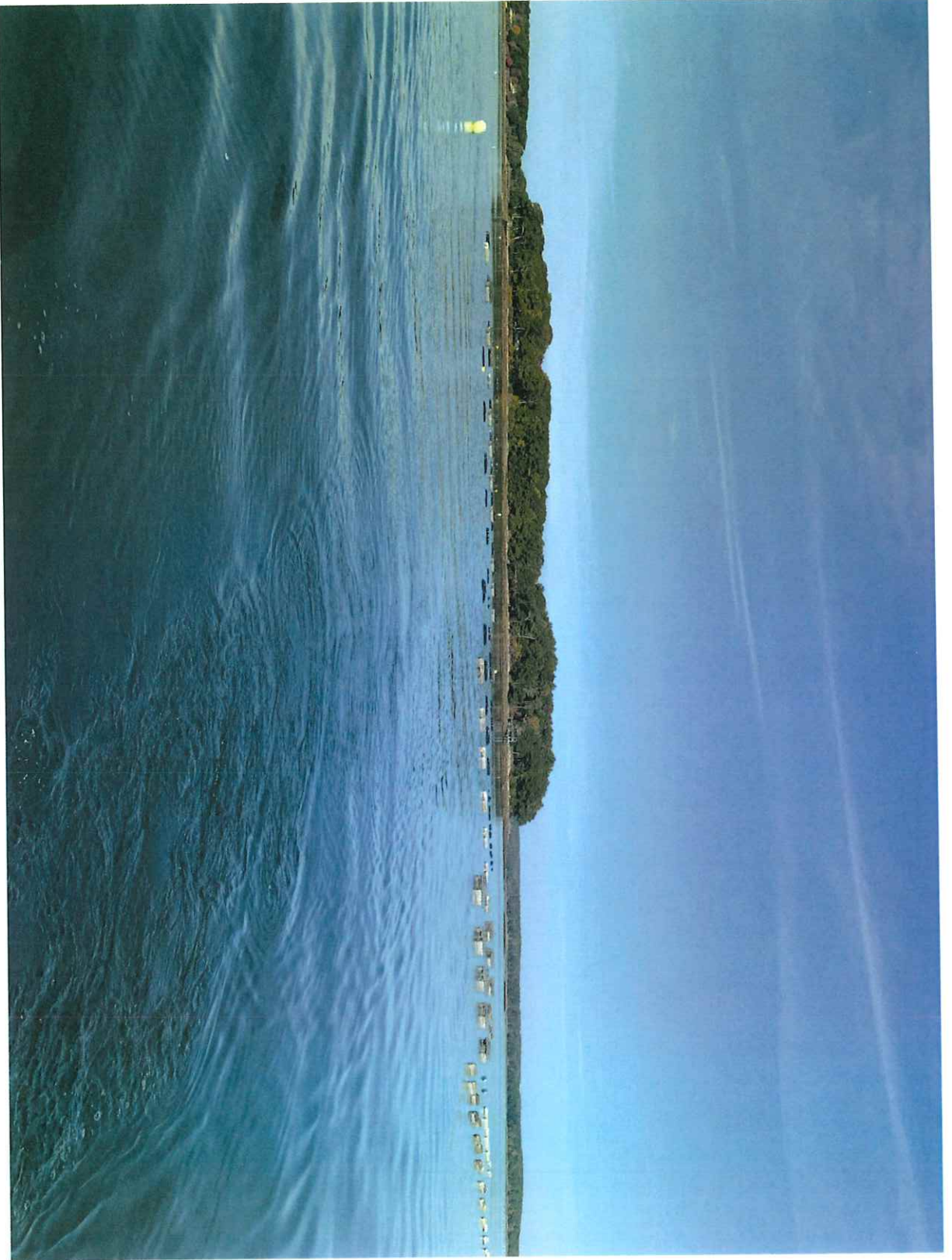

View from 43.768708, -70.118769  
Proposed gear would be orientated perpendicular to view seen in image.

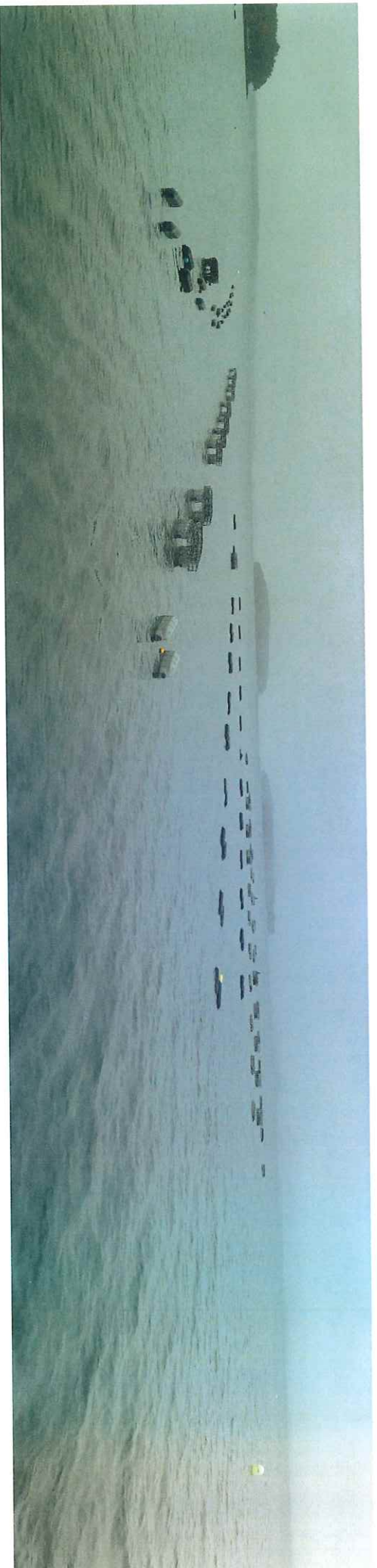

**Panoramic view from 43.768432, -70.119902**  
**Proposed gear orientation runs perpendicular to the existing view.**  
**The proposed standard lease extends 625' beyond the last line of**  
**cages (far right) seen in this image.**

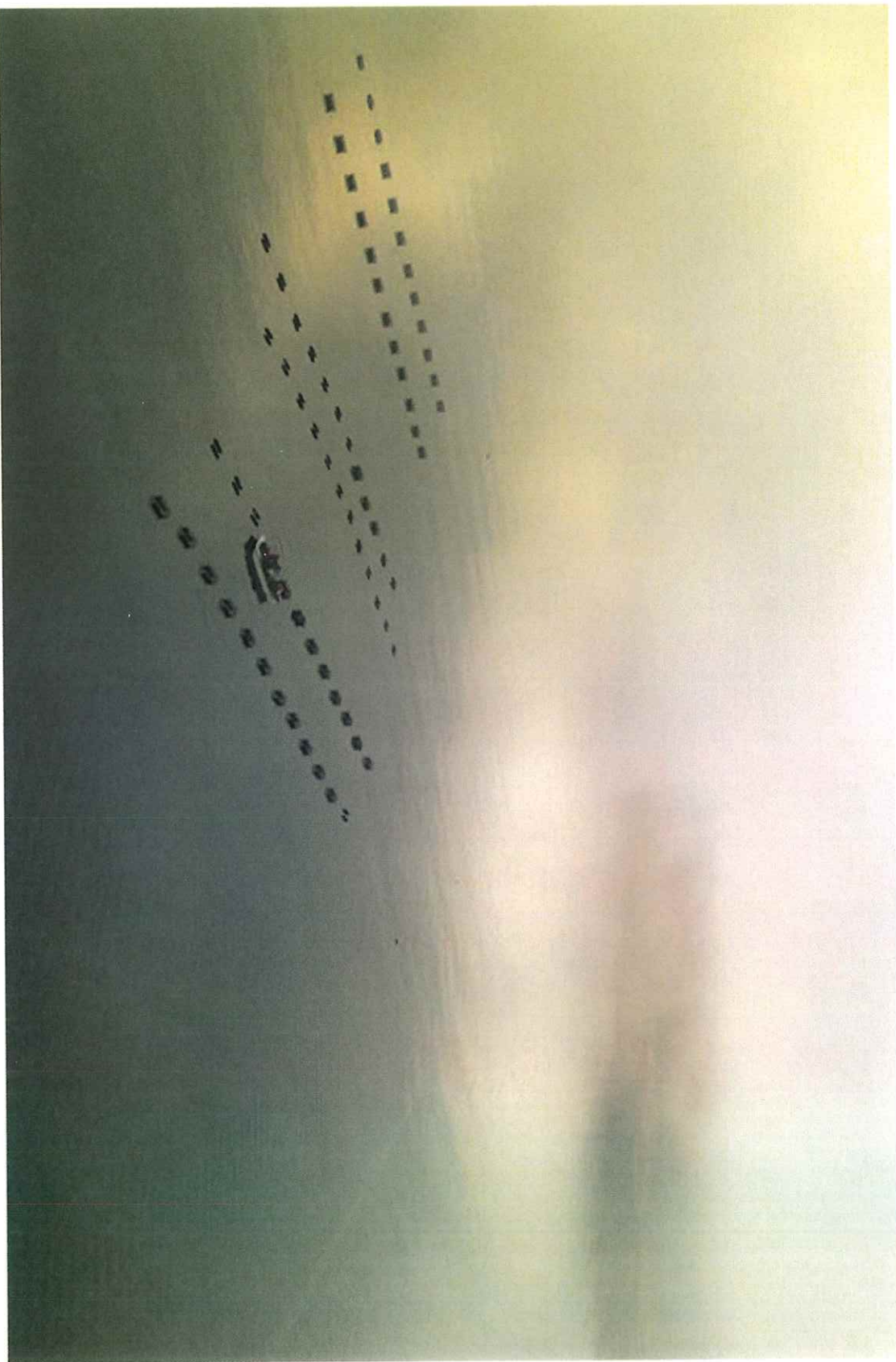

**Overhead drone image taken near 43.769819, -70.120292  
Proposed gear will run perpendicular to gear in image.**

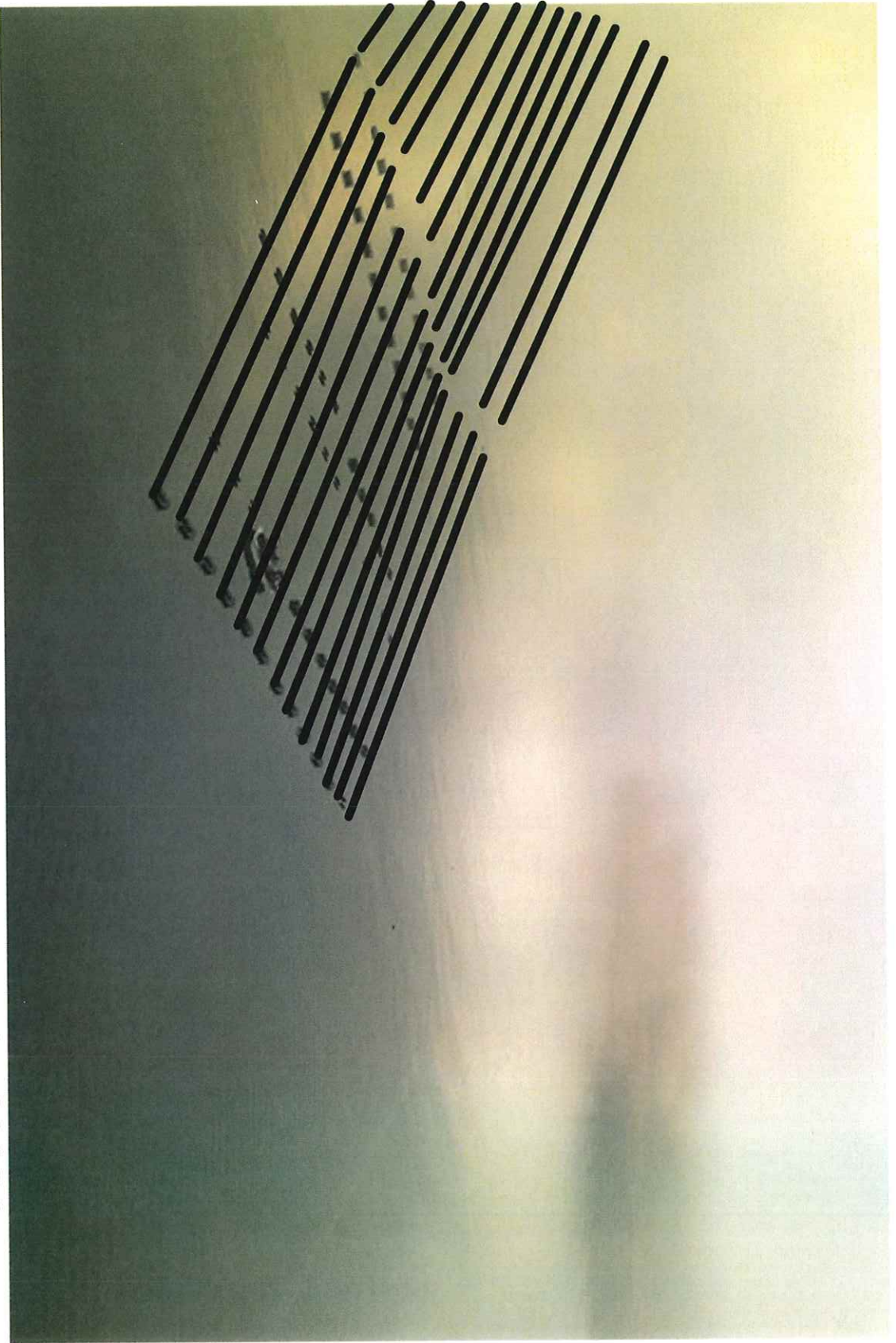

**Overhead drone image taken near 43.769819, -70.120292  
Proposed gear will run perpendicular to gear in image. Lines  
to show perpendicular orientation and extension of lease.**

## 8. PRODUCTION ACTIVITIES

**Directions:** If you are cultivating more than one species, you will need to provide the following information for each species. Please attach additional pages if needed.

**A.** Please explain your proposed seeding activities. What months will seeding occur and how often will you be onsite to seed during this time.

Oyster seeding depends on water temperature. 0.5" oysters will be placed in mesh bags, 6 bags per cage starting in July through October. Scallop seed will be placed in lantern nets (or in bags and cages) in April/May. Hard clams are seeded in the same manner as oysters, at the same time, in the same gear (in separate bags and cages).

**B.** Please explain your proposed tending/maintenance activities.

Cages are flipped once per week or less depending on the degree of bio-fouling. Lantern nets are raised by davit to be cleaned or to be exchanged for clean nets as often as Q 2-3 weeks as needed. Oyster and/or clam bags are removed from cages and taken to the work platform for tumbling and sorting. Tumbling, sorting and splitting of bags will occur as needed, weekdays.

**C.** How frequently will you visit the site for routine tending/maintenance (i.e. flipping cages, etc.)?

Aside from extreme weather events, the site will be tended 2 – 5 days per week throughout the majority of the growing season, June through November, less frequently during the winter.

**D.** Describe the harvesting techniques you will use. If you plan on using a drag, please provide the dimensions.

Harvesting is done by removing oysters or clams from bags. Scallops are removed from lantern nets. All species may also be in bottom cages such that harvesting is by raising cages off the bottom and removing the oysters, scallop or clams. In the future, with the wet storage float operational, market ready oysters may be removed from cages, placed in bags or baskets within the wet storage float.

**E.** How often will you be at the site during harvesting periods?

Harvesting is ongoing throughout the entire season, April – November. During growing season, June through November, it will co-occur with tumbling and sorting. Over the winter, harvesting will occur by raising bottom cages off the bottom or removing them from floating gear (as weather and ice permits) and removing oysters, clams and/or scallops once weekly or every other week.

**F.** Will gear be on the site year-round?  Yes  No

**G.** Describe any overwintering or “off season” plans for the site. For example, will you remove gear from the site and/or deploy gear in different areas within the proposed site? Please include where gear or product will be located if removed from the site.

OysterGro cages are typically sunk to the bottom for overwintering. Buoys will remain on surface. If ice does not occur, up to 100% of cages may remain floating over the winter (based on the specific year’s weather). Scallops are either transferred to bottom cages or may remain in floating lantern nets over the winter.

**H.** Please provide details on any predator control techniques you plan to employ.

A “bird away” kite may be employed, produced by OysterGro. The OysterGro mesh bags within wire cages are predator proof.

I. Suspended culture gear can attract birds that roost on the gear and defecate, potentially creating a pollution source impacting shellfish held within the gear. In order to comply with the National Shellfish Sanitation Program (NSSP) Model Ordinance (MO), DMR is requiring that applications for the suspended culture of shellfish include a description of mitigation or deterrent measures to minimize the potential pollution impacts of birds at the proposed site. If appropriate, include sketches or photos that clearly depict those measures put into practice.

Examples may include:

- Submerging suspended gear and associated product at a depth sufficient to deter roosting for two weeks before harvest
- Attaching physical deterrents (i.e. zip ties) to gear
- The site is proposed for the culture of seed only
- The site is proposed for the culture of adductor-only scallops (i.e. no other shellfish species would be grown on the site)
- Proposed gear would always be suspended below the surface of the water at a depth sufficient to deter roosting (i.e. as is common for scallop lantern nets)

We will deploy bird-away kites from July through October, 1 or 2 randomly repositioned weekly within the lease site. This is shown to be effective at preventing roosting.

## 9. NOISE AND LIGHT

**Directions:** If a question does not pertain to your proposed operations, please write “**not applicable**” or “N/A”.

A. What type of boats will be used on the site? When and how often will these vessels be on the site?

A 28 foot skiff (or smaller) with a 115 HP, 4 stroke (or smaller) engine will be on site 4 – 7 days per week during the growing season and approximately once weekly to every-other-week over the winter. We aim to utilize electric boat motors when possible.



**B.** What type of powered equipment (e.g. generator, power washer, grading equipment, barges, etc.) will be used on the site? When and how often will the equipment be used?

Tumbling and sorting is performed using a tumbler-sorter powered by a Honda EB 6500 generator. A wash down pump will be powered by either a 4 stroke gasoline engine or by a Honda WMP20 water pump. The tumbler-sorter may be used 1-5 days per week between 9am and 5 pm (May – October).

**C.** Specify how you intend to reduce noise levels from the boats and other powered equipment.

We limit the boat engines on the lease to smaller, 4 stroke outboards which are quiet and efficient. We hope to gradually replace gasoline motors with electric boat motors as a means of addressing noise pollution and further enhancing sustainability practices of our operations.

**D.** Provide the number, type (whether fixtures are shielded), wattage and location of lights, other than those used for navigation or marking, that will be used at the proposed lease site.

Not applicable. In a rare emergent weather situation demanding working after dark, headlamps would be used for light.

**E.** Indicate under what circumstances you might work at your site beyond daylight hours.

If a major storm is approaching, in an emergent situation, we may need to be at the lease after dark, sinking cages to the bottom (using head lamps). Usually there is sufficient warning to accomplish work during daylight hours.

## 10. CURRENT OPERATIONS

**Directions:** If a question does not pertain to your proposed operations, please write “**not applicable**” or “**N/A**”.

**A.** Describe your existing aquaculture operations, including the acronyms of all active leases and/or licenses.

We have an experimental lease (CAS LJ2x) within the area of the proposed lease and have 250,000 oysters currently in bags/cages. We had an LPA in the same area in 2018. Thomas Henninger has 2 LPAs south of the bridge to Cousins (THEN118, THEN418); Heidi Henninger has 2 LPAs adjacent (HHEN319, 419). We have an experimental lease at Broad Cove (CAS BC2x) with standard lease application pending. Thomas harvester lic 9336, Scallop spat 19603

**B.** What are your plans for any existing leases and/or Limited Purpose Aquaculture (LPA) licenses if the lease is granted? Will any existing leases and/or LPA licenses be relinquished if the lease is granted? If so, please indicate which ones.

The proposed lease will replace the current experimental lease at the same site, CAS LJ2x. The other projects will not be affected.

## 11. ENVIRONMENTAL CHARACTERIZATION

**Directions:** Using your knowledge of the area, describe the environment of the proposed lease site. Be sure to include units of measurement in your answers (i.e. feet, cm/s).

**A.** What are the approximate depths at mean low water?

8 – 12 feet

**B.** What are the approximate depths at mean high water?

16 – 20 feet

**C.** Provide the approximate current speed and direction during the ebb and flow.

North  $\leftrightarrow$  South at 0-2 knots

|   |
|---|
| <p><b>D.</b> The following questions (D.1 through D.6) may be answered in writing or by submitting a video. If you plan to submit a video, please contact the Department prior to video collection.</p>   |
| <p><b>1.</b> What are the bottom characteristics (mud, sand, gravel, rock, ledge or some mix, etc.)?</p>  |
| <p>Sticky mud</p>   |
| <p><b>2.</b> Describe the bottom topography (flat, steep rough, etc.).</p>  |
| <p>flat</p>   |
| <p><b>3.</b> Describe marine organisms by species or common names. Based on your personal observations or other sources of information, are these species abundant, common, or rare?</p>  |
| <p>Abundant skeleton shrimp, common ctenophores, sporadic mackerel, silversides</p>   |
| <p><b>4.</b> Are there shellfish beds or fish migration routes in the surrounding area? If so, please describe.</p>   |
| <p>No.</p>  |
| <p><b>5.</b> Describe the presence and extent of submerged aquatic vegetation, i.e. eelgrass, within the proposed lease area. Please include the date of this observation along with the method of observation. If submerged aquatic vegetation is observed, please also describe the abundance below and sketch the limits of the beds in the vicinity map.</p>                        |
| <p>No eelgrass has been observed on the site. Per DMR eelgrass map, there may be eelgrass near the site, more than 250 feet away to the south of the site in 4 feet of water. See vicinity map for visual. Our family (Nathaniel Henninger, Heidi Henninger) dove on the site several times during 2021 including summer and winter months, last was November 2021, Nate Henninger.</p> |

|   |
|---|
| <p><b>6.</b> Describe the general shoreline and upland characteristics (rocky shoreline, forested, residential, etc.)</p> |
| <p>The shore is mixed upland forest on the Little John side and residential dwelling on the Cousin's Island side.</p>     |

|   |
|---|
| <p><b>E.</b> Is your proposed lease located within a Maine Department of Inland Fisheries and Wildlife designated Essential Habitat?</p> <p><input type="checkbox"/> Yes <input checked="" type="checkbox"/> No</p> |
|---|

**Note:** The location of Essential Habitats in the State of Maine, along with information on how projects within these areas are reviewed, can be found here: <https://www.maine.gov/ifw/fish-wildlife/wildlife/endangered-threatened-species/essential-wildlife-habitat/index.html>

*If a project is located within an Essential Habitat*, applicants are strongly encouraged to contact the MDIFW Environmental Review Coordinator ([John.Perry@maine.gov](mailto:John.Perry@maine.gov), phone: 207-287-5254) prior to application submission.

**12. EXISTING USES**

|  |
|--|
| <p><b>A.</b> Describe the existing uses of the proposed area in questions A.1 through A.5 below. Please include the a) type b) time of year c) frequency and d) proximity to the lease site for each existing use.</p>   |
| <p><b>1. Commercial Fishing</b></p> <p>No commercial fishing has been observed at the proposed lease site. There have been a small number of lobster pots observed in the surrounding area over the summers of 2017 – 2021, none within the proposed lease site.</p> |
| <p><b>2. Recreational Fishing</b></p> <p>No recreational fishing has been observed within the area of the proposed lease. Minimal recreational fishing has been observed in the area outside of the cover around the northeast point of Little John Island.</p>      |

|   |
|---|
| <b>3. Boating Activities (please also include the distance to any navigable channel(s) from your proposed site at low water)</b>  |
| Sporadic boating has been observed in the summer. Most boaters venture in to reach the few nearby properties. The closest navigable channel from the site at low tide is 1300 feet to the east (23 foot depth). |
| <b>4. Ingress and egress (i.e. coming and going) of shorefront property owners within 1,000 feet of the proposal (e.g. docks, moorings, landing boats on shore, etc.)</b>                                       |
| The proposed lease site is sufficiently far from riparian landowner's docks that it will not affect ingress or egress.  |
| <b>5. Other uses (kayaking, swimming, etc.)</b>   |
| Kayaking and paddleboard traffic is light in this area.   |

|   |
|---|
| <b>B. Are there private docks, moorings, or other access points within 1,000 feet of the proposed lease? If yes, please include approximate distance from the proposed lease.</b> |
| No. The closest dock is over 1150 feet away.  |

|  |
|--|
| <b>C. Are there public beaches, parks, docking facilities or federally, state, or municipally conserved lands within 1,000 feet of the proposed lease site? If yes, please describe and include approximate distances from proposed lease.</b> |
| No.  |

**D.** Are there any Limited Purpose Aquaculture (LPA) licenses or aquaculture leases within 1,000 feet of your proposed lease site? If yes, please list their acronyms below.

Current and pending aquaculture leases and active LPA licenses may be found here:  
<https://www.maine.gov/dmr/aquaculture/leases/index.html>

HERR120  
HERR220  
AGAI121  
AGAI221

Experimental lease at 980 ft to the southwest: CAS LJ1x

### **13. EXCLUSIVE USE**

If your lease is granted, what activities would you request be excluded from occurring within the boundaries of the lease site? In your answer please address applicable commercial and recreational fishing, boating activities, and other activities you listed in the 'Existing Uses' section of this application.

We do not request that any activities be prohibited. Recreational boaters are welcome to approach and observe operations. Similarly, lobstermen are welcome to set their traps within the lease, taking care to avoid fouling of gear. Paddlers can easily navigate between the cages and are encouraged to do so.

#### 14. RIPARIAN LANDOWNERS AND SITE ACCESS

A. If your lease is within 1,000ft of shorefront land (**which extends to mean low water or 1,650 ft. from shore, whichever is less, according to NOAA charts**), the following supporting documents are required:

1. A labeled copy of a tax map(s) depicting the location of the proposed lease site and including the following elements:
  - Label the map “Tax Map: Town of (name of town).”
  - Legible scale
  - Tax lot numbers clearly displayed
  - The boundaries of the proposed lease
2. Please use the Riparian Landowner List (included on the next page) to list the name and address of every shorefront landowner within 1,000ft of the proposed lease site. Have the tax collector or clerk of the municipality certify the list. Refer to the riparian determination guidance document to ensure all riparian landowners are included:  
<https://www.maine.gov/dmr/aquaculture/forms/documents/RiparianDetermination.pdf>

*Note:* When the application and riparian list are both ready to be submitted, you may choose to email a copy of the riparian list and proposed lease coordinates to [DMRAquaculture@maine.gov](mailto:DMRAquaculture@maine.gov) for staff to verify that all required parcels are included on the list *before* having it certified by the municipality. DMR will not verify a riparian list multiple times, so please ensure there will be no additional changes to the application before emailing the riparian list for verification.

3. If any portion of the site is intertidal, you need to complete the steps outlined in the section titled: “19. Landowner/Municipal Permission Requirements”.

**B.** Will your access to the lease area be across riparian land?

Yes     No

**Note:** If you selected yes, you will need to complete the landowner permission requirements included in “19. Landowner/Municipal Permission Requirements” of this application.

**C.** How will you access the proposed site?

Boats launch from either Madeleine Point in Yarmouth or from Sea Meadows Marina on the Cousins River.

**D.** How will your proposed activities affect riparian ingress and egress?

Our activities will not affect riparian ingress or egress.

# Tax map: Town of Yarmouth.



★

160a



**RIPARIAN LANDOWNER LIST**

*\*THIS LIST MUST BE CERTIFIED\**

On this list, please show the current landowners' names and mailing addresses as listed in the municipal tax records for all riparian shorefront parcels within 1,000 feet of the proposed lease site along with the map and lot number for each parcel. **It is the applicant's responsibility to assemble the information for the Town Clerk to certify.** The Town Clerk *only* certifies that the information is correct according to the Town's records. Once you have completed the form, ask the Town Clerk to complete the certification section below. If the parcels are within more than one municipality, provide a separate, certified riparian list for each municipality.

**TOWN OF:** Yarmouth

| MAP # | LOT # | Landowner name(s) and address(es)                               |
|-------|-------|---|
| 60    | 2-2   | Karamanoglu Selcuk, 90 Cornfield Point Road, Yarmouth, ME 04096 |
|       |       |   |
|       |       |   |
|       |       |   |
|       |       |   |
|       |       |   |

**Please use additional sheets if necessary and attach hereto.**

**CERTIFICATION**

I, Jennifer S. Doten, Town Clerk for the Town of Yarmouth certify that the names and addresses of the property owners listed above, as well as the map and lot numbers, are those listed in the records of this municipality and are current as of this date.

**SIGNED:** Jennifer S. Doten **DATE:** 11/3/2022

## 15. TECHNICAL CAPABILITY

Provide information regarding professional expertise. Attaching resume or documentation of practical experience necessary to accomplish the proposed project would satisfy this requirement.

Thomas Henninger started working in the oystering business at age 11. He has a degree in biology and a 100 ton Captain's license. He has twice attended the Aquaculture in Shared Waters (AQS)W) course offered by Sea Grant and completed AQS)W) 2.0. Thomas possesses an aquaculture license, 9336, a shellfish dealer's license (ME 17617-SS), a sea scallop spat collection license (19603). Each member of the Henninger is a certified open ocean diver. As the owner of Madeleine Point Oyster Farms, Thomas has been selling market oysters since 2019.

## 16. FINANCIAL CAPABILITY

### A. Financial Capability

Please provide documentation to show you have the financial resources to implement the proposal. For example, you may submit a letter from a financial institution or funding agency indicating that you have an account in good standing, or their willingness to commit funds.

**Note:** Any financial information you submit with your application is part of the public record. Please exercise discretion when submitting financial information.

Our Business account is at Bath Savings in Yarmouth, ME. Submitted is a letter of good standing. We also submitted letters from our funding partner, CEI. We have just paid off our first loan from FAME; enclosed is the letter of debt repayment in full.

### B. Cost Estimates

Please provide cost estimates of the proposed aquaculture activities.

Most of the capital investment creating the infrastructure of the farm has been completed. The primary future costs are for the cages and bags needed to increase from our current capacity, \$100,000. Our boat, trailer, engine, production equipment are new so operational expenses will be covered by sales of produce.

## 17. ESCROW ACCOUNT OR PERFORMANCE BOND

Check the category that describes your operation:

| Check Here                          | Lease Category                                    | Amount of Required Escrow or Performance Bond |
|-------------------------------------|---|---|
| <input type="checkbox"/>            | No gear/structure, no discharge                   | \$500.00                                      |
| <input type="checkbox"/>            | No gear/structure, discharge                      | \$500.00                                      |
| <input type="checkbox"/>            | ≤ 400 square feet of gear/structure, no discharge | \$1,500.00                                    |
| <input checked="" type="checkbox"/> | >400 square feet of gear/structure, no discharge  | \$5,000.00*                                   |
| <input type="checkbox"/>            | Gear/Structure, discharge                         | \$25,000.00                                   |

\*DMR may increase the bond/escrow requirements for leases with more than 2,000 square feet of structure.

I, (*printed name of applicant*) Thomas Henninger have read DMR Aquaculture Regulations Chapter 2.64(10) (D) and if this proposed lease is granted by DMR, I will either open an escrow account or obtain a performance bond, in the amount determined by the lease category.

  
 \_\_\_\_\_

**Applicant Signature**

*Note: Add title if signing on behalf of a corporate applicant.*

03/28/2022 \_\_\_\_\_

**Date**

**ADDITIONAL APPLICANTS:** Each applicant must sign this section indicating that they will open an escrow account or obtain a performance bond. Use the space below for additional persons listed on the application. You may attach additional pages, if necessary.

I, (*printed name of applicant*) \_\_\_\_\_ have read DMR Aquaculture Regulations Chapter 2.64(10) (D) and if this proposed lease is granted by DMR, I will either open an escrow account or obtain a performance bond, in the amount determined by the lease category.

\_\_\_\_\_  
**Applicant Signature**

*Note: Add title if signing on behalf of a corporate applicant.*

\_\_\_\_\_  
**Date**

**18. APPLICANT SIGNATURE PAGE**

I hereby state that the information included in this application is true and correct. I have also read and understand the requirements of the Department's rules governing aquaculture and the application instructions pertaining to the standard lease process.

Printed name Thomas Henninger \_\_\_\_\_

Title (if corporate applicant): N/A \_\_\_\_\_

Signature:  \_\_\_\_\_ Date: 03/28/2022 \_\_\_\_\_

18 U.S.C. Section 1001 provides that: Whoever, in any manner within the jurisdiction of any department or agency of the United States knowingly and willfully falsifies, conceals, or covers up any trick, scheme, or disguises a material fact or makes any false, fictitious or fraudulent statements or representations or makes or uses any false writing or document knowing same to contain any false, fictitious or fraudulent statements or entry, shall be fined not more than \$10,000 or imprisoned not more than five years or both.

**Note:**

- All applicants must sign and date this page. Please use the space below, if additional signatures are required.
- Corporate applicants, please be sure to include the title(s) (i.e. President, Treasurer, etc.) of the individual(s) signing on the company's behalf.

**Additional Applicant:**

Printed name: \_\_\_\_\_

Title (if corporate applicant): \_\_\_\_\_

Signature: \_\_\_\_\_ Date: \_\_\_\_\_

**19. LANDOWNER/MUNCIPAL PERMISSION REQUIREMENTS (if applicable) N/A**  
**Directions:** If any portion of the site is intertidal, you need to complete the steps outlined below.

**Step I: Obtain written permission from all intertidal landowners.**

Pursuant to DMR Regulations Chapter 2.10(3)(G) the Department requires *written permission of every owner of intertidal land in, on, or over which the activity will occur.* It is your responsibility to obtain written permission and include it with your application materials. Please note that the Department does not provide forms for landowner permission.

**Step II: Determine if the municipality where your site is located has a shellfish conservation program.**

Pursuant to 12 MRSA §6072(3) *In any municipality with a shellfish conservation program under section 6671, the Commissioner may not lease areas in the **intertidal zone** within the municipality without the consent of the municipal officers.*

If the municipality where the proposed lease site is located has a shellfish conservation program, it is your responsibility to obtain consent for the proposed lease site from the municipal officers (i.e. the selectmen or councilors of the town, or the mayor and aldermen or councilors of a city.) Consent means a majority vote of the municipal officers as recorded in a public meeting.

It is your responsibility to contact the municipality and determine if they have a shellfish conservation program. Best practices would include discussing your plans with shellfish committee members, but only the consent of municipal officers is required.

|   |
|---|
| Does the municipality, where the proposed site is located, have a shellfish conservation program? <input type="checkbox"/> Yes <input checked="" type="checkbox"/> No |
|---|

**If you answered yes,** please attach documentation from a public meeting demonstrating that a majority of municipal officers have consented to your proposal.



December 13, 2021

To Whom It May Concern,

This letter is to acknowledge the relationship between SeaChange LLC dba Madeleine Point Oyster Farms and Coastal Enterprises Inc., CEI. SeaChange LLC has had a relationship with CEI starting in 2018 and securing initial funding in 2019. SeaChange LLC has maintained a perfect repayment history with CEI, and we consider the company to be in good standing.

Respectfully Submitted,

Molly C. Gerencer

Loan and Investment Officer



February 23, 2022

SeaChange, LLC  
Thomas Henninger  
Heidi Henninger  
492 W. Elm Street  
Yarmouth, ME 04096

RE: Agricultural Marketing Loan Fund Loan

Dear Mr. Henninger and Dr. Henninger:

Our records show that your Agricultural Marketing Loan Fund loan has been paid in full. Attached are the following:

- 1) The original Promissory Note stamped "PAID IN FULL".
- 2) A copy of the Discharge of Mortgage, which has been sent to the Cumberland County Registry of Deeds for filing. The original Discharge should be returned directly to you from the Registry.
- 3) A copy of the Satisfaction or Release of Mortgage, which has been sent (by email) to the National Vessel Documentation Center for filing.
- 4) A refund of final overpayment in the amount of \$537.12.

Please take a few minutes to contact your insurance agent and request that the lien holder/mortgagee/loss payee be removed from the policy.

On behalf of the Agricultural Marketing Loan Fund, Department of Agriculture, Conservation and Forestry and Commissioner Amanda E. Beal, we want to thank you for your timely payment of this obligation.

Sincerely,

A handwritten signature in cursive script that reads "Laurie Garrison".

Laurie Garrison  
Commercial Loan Assistant

/LG  
Enclosures (3)