

## STANDARD LEASE APPLICATION: NON-DISCHARGE

### 1. APPLICANT CONTACT INFORMATION

Applicant	Summit Point LLC		
Contact Person	Colleen Francke		
Address	1 Shady Lane		
City	Falmouth		
State, Zip	Maine, 04105		
County	Cumberland		
Telephone	207-615-1457		
Email	summitpointseafood@yahoo.com		
Type of Application	<input checked="" type="checkbox"/> Draft Application <small>[submitted before scoping session session]</small>		<input type="checkbox"/> Final Application <small>[submitted after scoping session]</small>
Dates	Pre-Application Meeting: 4/12/22	Draft Application Submitted: 5/4/22	Scoping Session:
Payment Type	Draft Application: <input checked="" type="checkbox"/> Check (included) <input type="checkbox"/> Credit Card		Final Application: <input type="checkbox"/> Check (included) <input type="checkbox"/> Credit Card

### 2. PROPOSED LEASE SITE INFORMATION

Location of Proposed Lease Site	
Town	Yarmouth
Waterbody	Casco Bay
General Description (e.g. south of B Island)	South of the Nubbin
Lease Information	
Total acreage requested (100-acre maximum)	9.3
Lease term requested (20-year maximum)	20 years
Type of culture (check all that apply)	<input type="checkbox"/> Bottom (no gear) <input checked="" type="checkbox"/> Suspended (gear in the water and/or on the bottom)
Is any portion of the proposed lease site above mean low water?	<input type="checkbox"/> Yes <input checked="" type="checkbox"/> No

### 3. GROWING AREA DESIGNATION

Growing Area Designation (e.g. WL):	WI
Growing Area Section (e.g. "A1"):	Inset B "open/approved"

### 4. SPECIES INFORMATION

A. Please complete the table below and add additional rows as needed.

Name of species to be cultivated (include both common and scientific names):	Name and address of the source of seed stock or juveniles	Maximum number (or biomass) of organisms you anticipate on the site at any given time
1. Sugar Kelp: <i>Saccharina Latissima</i>	Summit Point LLC 1 Shady Lane Falmouth, ME. 04105	0-73,500 wet lbs. depending on the time of year and growing season.
2. Skinny Kelp: <i>Saccharina Angustissima</i>	Summit Point LLC 1 Shady Lane Falmouth, ME. 04105	0-73,500 wet lbs. depending on the time of year and growing season.
3.		
4.		
5.		

B. Do you intend to possess, transport, or sell whole or roe-on scallops?  Yes  No

## 5. VICINITY MAP

Please See "Vicinity Map" attached: page 22

## 6. BOUNDARY DRAWING

Please See "Boundary Drawing" attached: page 23

### Directions:

Coordinate Description: Generated using the aquaculture web map found at the DMR website.

Please See "Coordinate Description" attached: page 24

NW: 43.757561  
-70.175711

NE: 43.756951  
-70.174431

SW: 43.755297  
-70.177856

SE: 43.754693  
-70.176590

## 7. SITE DEVELOPMENT

### A. Gear Information

Please See:

- "Gear drawing- depth control buoys" attached: page 25
- "Gear drawing- sink rope for depth control buoys" attached: page 26
- "Gear drawing- small weight for depth control buoys" attached: page 27
- "Gear drawing- long line" attached: page 28
- "Gear drawing- mooring marker" attached: page 29
- "Gear drawing- mooring line" attached: page 30
- "Gear drawing- mooring" attached: page 31
- "Gear drawing- mooring staple" attached: page 32
- "Gear drawing- line connecting moorings" attached: page 33
- "Gear drawing- shackle" attached: page 34
- "Gear drawing- corner mooring marker" attached: page 35

Specific Gear Type (e.g. soft mesh bag)	Dimensions (e.g. 16"x20"x2")	Time of year gear will be deployed (e.g. Spring, Winter, etc.)	Maximum amount of this gear type that will be deployed on the site (i.e. 200 cages, 100 lantern nets, etc.)	Species that will be grown using this gear type
Depth control buoys	7x11"	Nov 1 <sup>st</sup> -June 1 <sup>st</sup>	441 buoys (9 per long line)	Sugar kelp/Skinny kelp
Sink rope for depth control buoys	7 feet long by 3/8" diameter	Nov 1 <sup>st</sup> -June 1 <sup>st</sup>	441 pieces	Sugar kelp/Skinny kelp
Small weight for depth control buoys	2x2x6"	Nov 1 <sup>st</sup> -June 1 <sup>st</sup>	441 weights	Sugar kelp/Skinny kelp
Long line	7/16" diameter 360' long	Nov 1 <sup>st</sup> -June 1 <sup>st</sup>	49 individual lines Totaling 17,640'	Sugar kelp/Skinny kelp
Mooring marker (hard-shell variety)	16" diameter (white)	Nov 1 <sup>st</sup> -June 1 <sup>st</sup>	94 mooring markers	Sugar kelp/Skinny kelp
Mooring line	1" diameter by varying lengths depending on depth of mooring	Nov 1 <sup>st</sup> -June 1 <sup>st</sup> (Except 4 left in year round for "corner mooring markers")	98 mooring lines	Sugar kelp/Skinny kelp
Mooring (concrete block)	2'x2'x2'	Year-round	98 blocks	Sugar kelp/Skinny kelp

Mooring Staple	3 links of 1" diameter chain	Year-round	98 staples	Sugar kelp/Skinny kelp
Line connecting moorings	½" diameter sink By 960' long	Year-round	2 lengths of line 960' long	Sugar kelp/Skinny kelp
Shackle	1 ¼"	Nov 1 <sup>st</sup> -June 1 <sup>st</sup> (4 left in year-round)	98 Shackles	Sugar kelp/Skinny kelp
Corner mooring marker (LD-2 yellow poly ball with reflective tape)	11.5x24"	Year-round	4 corner mooring markers	Sugar kelp/Skinny kelp

**B. Maximum Structure and Mooring System Schematic**

Please See:

“Overhead View” attached: page 36

“Key for Overhead View” attached: page 37

“Overhead View Seasonal Changes” attached: page 38

“Key for Overhead View Seasonal Changes” attached: page 39

“Cross-Section View” attached: page 40-42

“Key for Cross-Section View” attached: page 43

“Cross-Section View Seasonal Changes” attached: page 44-46

“Key for Cross-Section View Seasonal Changes” attached: page 47

**C. On-Site Support Structures**

1. Describe structures such as barges, sheds, etc., to be located on-site. Provide a schematic and indicate the dimensions, including height above sea level, materials, etc.

No structures will be located on the site

2. Describe the storage and use of oil, gasoline, or other hazardous materials on site. If petroleum products are to be stored on site, provide a spill prevention plan.

No oil, gasoline, or hazardous materials will be stored on site. Boat refueling will be done off site. Absorbent clothes will be stored on board in case of any emergency engine leaks or spills.

**D. Gear Color**

Provide the color of the gear and structures proposed to be used at the lease site.

Corner mooring markers will be yellow with reflective tape. All mooring markers will be white. The two-inch tall "Sea farm" lettering on the corner mooring markers and mooring markers will be black. The depth control buoys will be white and labeled "farm" with black lettering. The long lines and line for depth control buoys will be white.

**E. Equipment Layout**

-See "Equipment Layout 1" attached: page 48

-See "Equipment Layout 2" attached: page 49

**F. Marking**

Will you be able to mark your site in accordance with DMR regulations, Chapter 2.80? In part, this requires marker buoys which clearly display the lease ID and the words SEA FARM to be located at each corner of the lease.

Yes  No

If you answered no, explain why and suggest alternate markings.

## 8. PRODUCTION ACTIVITIES

**A.** Please explain your proposed seeding activities. What months will seeding occur and how often will you be onsite to seed during this time.

Seeding begins Nov 1<sup>st</sup> at the earliest. I use a small Carolina Skiff to attach the long lines to the moorings while simultaneously planting the kelp seed. This process goes relatively quickly and can be completed in a few days to a week if the weather is cooperative. The latest that we will outplant seed is the beginning of January if there are weather complications or seed delays from the hatchery. All seeding will be done during daylight hours only.

**B.** Please explain your proposed tending/maintenance activities.

The kelp will be checked a couple times a week during daylight hours only. We will use either a Carolina skiff or a lobster boat to check the site. During this time, we measure the kelp's growth, check that the equipment is submerged to its proper depth, and make sure the site is in good repair.

**C.** How frequently will you visit the site for routine tending/maintenance (i.e. flipping cages, etc.)?

Typically, the site will only be visited a couple times a week for routine monitoring.

**D.** Describe the harvesting techniques you will use. If you plan on using a drag, please provide the dimensions.

The kelp will be harvested in April or May depending on its quality and growth. All of the kelp and seasonal gear will be removed from the site by June 1<sup>st</sup>. Harvest could take place for up to seven days a week until its completion.

We will use a lobster boat and a small Carolina skiff to harvest the site. The kelp lines will be hoisted onto the lobster boat using reels and a hoist where it will be trimmed and packed for transport to shore.



**E.** How often will you be at the site during harvesting periods?

We may be at the site up to seven days a week during harvest. We will work daylight hours only.

**F.** Will gear be on the site year-round?  Yes  No

Almost all of the surface gear will be removed from June 1<sup>st</sup>-November 1<sup>st</sup>.

**G.** Describe any overwintering or “off season” plans for the site. For example, will you remove gear from the site and/or deploy gear in different areas within the proposed site? Please include where gear or product will be located if removed from the site.

All seasonal gear including long lines, depth control buoys, line for depth control buoys, small weights, and all the mooring markers and corresponding mooring lines and shackles will be removed from the site by June 1<sup>st</sup>. Seasonal gear will be stored either on land or on my commercial float located off-site.

Only the cement moorings and for yellow “corner mooring markers” with reflective tape will remain on site year-round.

**H.** Please provide details on any predator control techniques you plan to employ.

We do not use predator control techniques.

**I.** Suspended culture gear can attract birds that roost on the gear and defecate, potentially creating a pollution source impacting shellfish held within the gear. In order to comply with the National Shellfish Sanitation Program (NSSP) Model Ordinance (MO), DMR is requiring that applications for the suspended culture of shellfish include a description of mitigation or deterrent measures to minimize the potential pollution impacts of birds at the proposed site. If appropriate, include sketches or photos that clearly depict those measures put into practice.

Examples may include:

- Submerging suspended gear and associated product at a depth sufficient to deter roosting for two weeks before harvest
- Attaching physical deterrents (i.e. zip ties) to gear
- The site is proposed for the culture of seed only
- The site is proposed for the culture of adductor-only scallops (i.e. no other shellfish species would be grown on the site)
- Proposed gear would always be suspended below the surface of the water at a depth sufficient to deter roosting (i.e. as is common for scallop lantern nets)

NA

## 9. NOISE AND LIGHT

**A.** What type of boats will be used on the site? When and how often will these vessels be on the site?

Boats that will be used on the site include a small Carolina skiff, a lobster style boat, and a small mooring placement barge and aluminum skiff.

-The Carolina skiff will be used for seeding, routine maintenance, and harvest.

-The lobster boat will be used for harvest and possibly routine maintenance visits.

-The small barge and aluminum skiff will be used during the mooring installation.

**B.** What type of powered equipment (e.g. generator, power washer, grading equipment, barges, etc.) will be used on the site? When and how often will the equipment be used?

A Carolina skiff will be used for seeding, routine maintenance, and harvest.

A small push barge with aluminum skiff will be used during mooring installation. The barge uses a small pull start motor that operates a winch. The motor is housed in a sound muffling box.

All harvest equipment is contained on the lobster boat.

**C.** Specify how you intend to reduce noise levels from the boats and other powered equipment.

Mufflers and sound reduction box on barge.

**D.** Provide the number, type (whether fixtures are shielded), wattage and location of lights, other than those used for navigation or marking, that will be used at the proposed lease site.

There will be no lights at this site unless deemed necessary by the Coast Guard for navigation.

**E.** Indicate under what circumstances you might work at your site beyond daylight hours.

We would only work beyond daylight hours in the event of an emergency.

## 10. CURRENT OPERATIONS

**A.** Describe your existing aquaculture operations, including the acronyms of all active leases and/or licenses.

CAS SI2- Kelp farm

**B.** What are your plans for any existing leases and/or Limited Purpose Aquaculture (LPA) licenses if the lease is granted? Will any existing leases and/or LPA licenses be relinquished if the lease is granted? If so, please indicate which ones.

I intend to keep my lease active and working.

## 11. ENVIRONMENTAL CHARACTERIZATION

**A.** What are the approximate depths at mean low water?

Approximately, there is 22 feet of water at low tide.

**B.** What are the approximate depths at mean high water?

Approximately, there is 33 feet of water at high tide.

**C.** Provide the approximate current speed and direction during the ebb and flow.

To the best of my knowledge there is no more than 2 knots of tide at this site, which travels on close to a North to South Direction.

**D.** The following questions (D.1 through D.6) may be answered in writing or by submitting a video. If you plan to submit a video, please contact the Department prior to video collection.

<p><b>1. What are the bottom characteristics (mud, sand, gravel, rock, ledge or some mix, etc.)?</b></p>
<p>The bottom is soft mud.</p>
<p><b>2. Describe the bottom topography (flat, steep rough, etc.).</b></p>
<p>The bottom is flat.</p>
<p><b>3. Describe marine organisms by species or common names. Based on your personal observations or other sources of information, are these species abundant, common, or rare?</b></p>
<p>From my personal observation:</p> <p>Lobster- rare Crab- abundant</p>
<p><b>4. Are there shellfish beds or fish migration routes in the surrounding area? If so, please describe.</b></p>
<p>To the best of my knowledge there are no shellfish beds or fish migration routes in this area.</p>
<p><b>5. Describe the presence and extent of submerged aquatic vegetation, i.e. eelgrass, within the proposed lease area. Please include the date of this observation along with the method of observation. If submerged aquatic vegetation is observed, please also describe the abundance below and sketch the limits of the beds in the vicinity map.</b></p>
<p>There is no submerged aquatic vegetation or eelgrass within the proposed site based on the 2018 eelgrass mapping tool found on the DMR aquaculture web map.</p>

**6.** Describe the general shoreline and upland characteristics (rocky shoreline, forested, residential, etc.)

The nearest shoreline is Nubbin Island, which is a small rocky island covered in low bushes. It is owned by The State of Maine.

**E.** Is your proposed lease located within a Maine Department of Inland Fisheries and Wildlife designated Essential Habitat?

Yes  No

The MDIFW Environmental Review Coordinator has been contacted. They intend to do a formal review of the area once this application is deemed complete

-See "Maine Department of Inland Fisheries and Wildlife review" attached: page 50

## 12. EXISTING USES

**A.** Describe the existing uses of the proposed area in questions A.1 through A.5 below. Please include the a) type b) time of year c) frequency and d) proximity to the lease site for each existing use.

### 1. Commercial Fishing

- a. lobstering/Menhaden fishing
- b. late spring-summer
- c. infrequent
- d. within

### 2. Recreational Fishing

- a. hook fishing
- b. summer
- c. infrequent
- d. within

<p><b>3. Boating Activities (please also include the distance to any navigable channel(s) from your proposed site at low water)</b></p> <p>a. sail/pleasure  b. late spring-early fall  c. moderate  d. within</p>
<p><b>4. Ingress and egress (i.e. coming and going) of shorefront property owners within 1,000 feet of the proposal (e.g. docks, moorings, landing boats on shore, etc.)</b></p> <p>There is no ingress or egress of shorefront property owners within 1,000 feet of the proposal.</p>
<p><b>5. Other uses (kayaking, swimming, etc.)</b></p> <p>a. kayaking  b. late spring-early fall  c. moderate  d. within</p>

<p><b>B. Are there private docks, moorings, or other access points within 1,000 feet of the proposed lease? If yes, please include approximate distance from the proposed lease.</b></p>
<p>The Southern tip of the Yarmouth “Special Anchorage 110.1 &amp; 110.5” is located approximately 500 feet from the Northern end of the proposal. There are no private docks or other access points within 1,000 feet</p>

<p><b>C. Are there public beaches, parks, docking facilities or federally, state, or municipally conserved lands within 1,000 feet of the proposed lease site? If yes, please describe and include approximate distances from proposed lease.</b></p>
<p>There are no public beaches, parks, docking facilities or federally or municipally conserved lands within 1,000 feet of the proposal. The Nubbin is owned by The State of Maine, and is approximately 200’ away from the proposal.</p>

**D.** Are there any Limited Purpose Aquaculture (LPA) licenses or aquaculture leases within 1,000 feet of your proposed lease site? If yes, please list their acronyms below.

Current and pending aquaculture leases and active LPA licenses may be found here: <https://www.maine.gov/dmr/aquaculture/leases/index.html>

There are no LPA's or other aquaculture leases within 1,000 feet of the proposal.

### 13. EXCLUSIVE USE

If your lease is granted, what activities would you request be excluded from occurring within the boundaries of the lease site? In your answer please address applicable commercial and recreational fishing, boating activities, and other activities you listed in the 'Existing Uses' section of this application.

Although this would be outside of the normal activities in this area during this timeframe, I ask for no lobster or crab fishing and no hook fishing from Nov 1<sup>st</sup>- June 1<sup>st</sup>.

Although this is not an area where fishermen drag. I ask for no dragging year-round due to the "rope less" mooring system I will be deploying.



**14. RIPARIAN LANDOWNERS AND SITE ACCESS**

**A.**

1. Please See "Tax Map" attached: page 51
2. Please See "Riparian owners list" attached: page 52

**B.** Will your access to the lease area be across riparian land?

Yes     No

**C.** How will you access the proposed site?

Falmouth Town Landing or Portland waterfront.

**D.** How will your proposed activities affect riparian ingress and egress?

My activities will not affect riparian ingress and egress.

## 15. TECHNICAL CAPABILITY

Provide information regarding professional expertise. Attaching resume or documentation of practical experience necessary to accomplish the proposed project would satisfy this requirement.

My existing lease CAS SI2 shows that I have the practical and professional experience and expertise necessary to accomplish the proposed project.

## 16. FINANCIAL CAPABILITY

### A. Financial Capability

Please provide documentation to show you have the financial resources to implement the proposal. For example, you may submit a letter from a financial institution or funding agency indicating that you have an account in good standing, or their willingness to commit funds.

**Note:** Any financial information you submit with your application is part of the public record. Please exercise discretion when submitting financial information.

I am in good standing with Farm Credit and have available funds for this proposal.

-See "Farm Credit letter" attached: page: 53

### B. Cost Estimates

Please provide cost estimates of the proposed aquaculture activities.

This proposal will cost approximately \$30,000 to install.

**17. ESCROW ACCOUNT OR PERFORMANCE BOND**

Check the category that describes your operation:

Check Here	Lease Category	Amount of Required Escrow or Performance Bond
<input type="checkbox"/>	No gear/structure, no discharge	\$500.00
<input type="checkbox"/>	No gear/structure, discharge	\$500.00
<input type="checkbox"/>	≤ 400 square feet of gear/structure, no discharge	\$1,500.00
<input checked="" type="checkbox"/>	>400 square feet of gear/structure, no discharge	\$5,000.00*
<input type="checkbox"/>	Gear/Structure, discharge	\$25,000.00

\*DMR may increase the bond/escrow requirements for leases with more than 2,000 square feet of structure.

I, (*printed name of applicant*) Colleen Francke on behalf of Summit Point LLC have read DMR Aquaculture Regulations Chapter 2.64(10) (D) and if this proposed lease is granted by DMR, I will either open an escrow account or obtain a performance bond, in the amount determined by the lease category.

Colleen Francke owner of Summit Point LLC  
**Applicant Signature**

5/4/22  
**Date**

*Note: Add title if signing on behalf of a corporate applicant.*

**ADDITIONAL APPLICANTS:** Each applicant must sign this section indicating that they will open an escrow account or obtain a performance bond. Use the space below for additional persons listed on the application. You may attach additional pages, if necessary.

I, (*printed name of applicant*) NA have read DMR Aquaculture Regulations Chapter 2.64(10) (D) and if this proposed lease is granted by DMR, I will either open an escrow account or obtain a performance bond, in the amount determined by the lease category.

NA  
**Applicant Signature**

NA  
**Date**

*Note: Add title if signing on behalf of a corporate applicant.*

**18. APPLICANT SIGNATURE PAGE**

**-Please See "Corporate application" attached: page 54 - 57**

**-Please See "Articles of formation" attached: page 58 - 59**

I hereby state that the information included in this application is true and correct. I have also read and understand the requirements of the Department's rules governing aquaculture and the application instructions pertaining to the standard lease process.

Printed name: Colleen Francke

Title (if corporate applicant): Owner of Summit Point LLC

Signature:  Date: 5/4/22

18 U.S.C. Section 1001 provides that: Whoever, in any manner within the jurisdiction of any department or agency of the United States knowingly and willfully falsifies, conceals, or covers up any trick, scheme, or disguises a material fact or makes any false, fictitious or fraudulent statements or representations or makes or uses any false writing or document knowing same to contain any false, fictitious or fraudulent statements or entry, shall be fined not more than \$10,000 or imprisoned not more than five years or both.

**19. LANDOWNER/MUNCIPAL PERMISSION REQUIREMENTS**

NA. Proposal is not intertidal

Does the municipality, where the proposed site is located, have a shellfish conservation program?  Yes  No

# Vicinity MAP:

FROM QUESTION 5

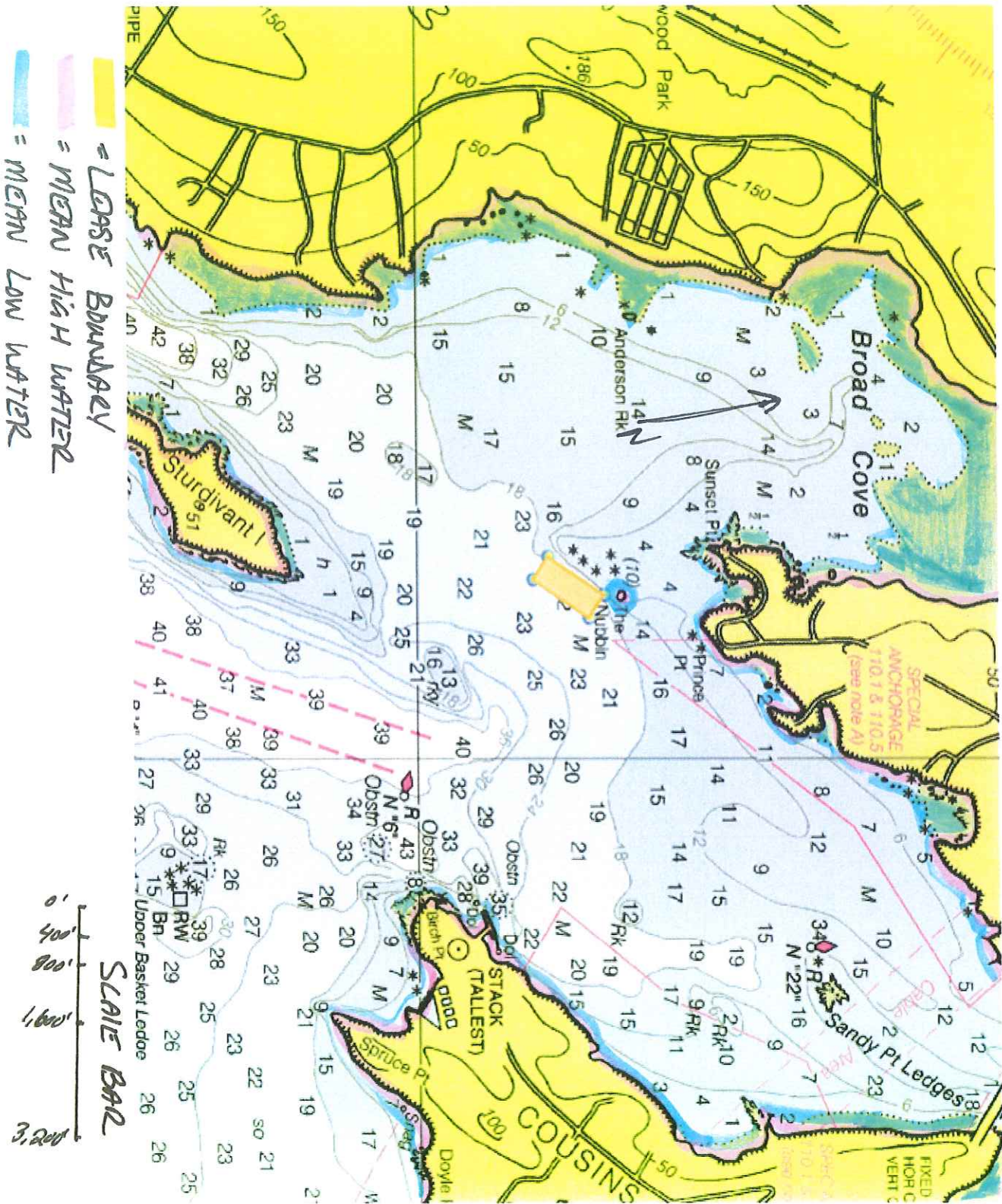

# BOUNDARY DRAWING:

FROM ORIENTATION 6

- = NW CORNER
- = NE CORNER
- = SW CORNER
- = SE CORNER

- ▬ = LEASE BOUNDARY
- ▬ = DISTANCE BETWEEN CORNERS

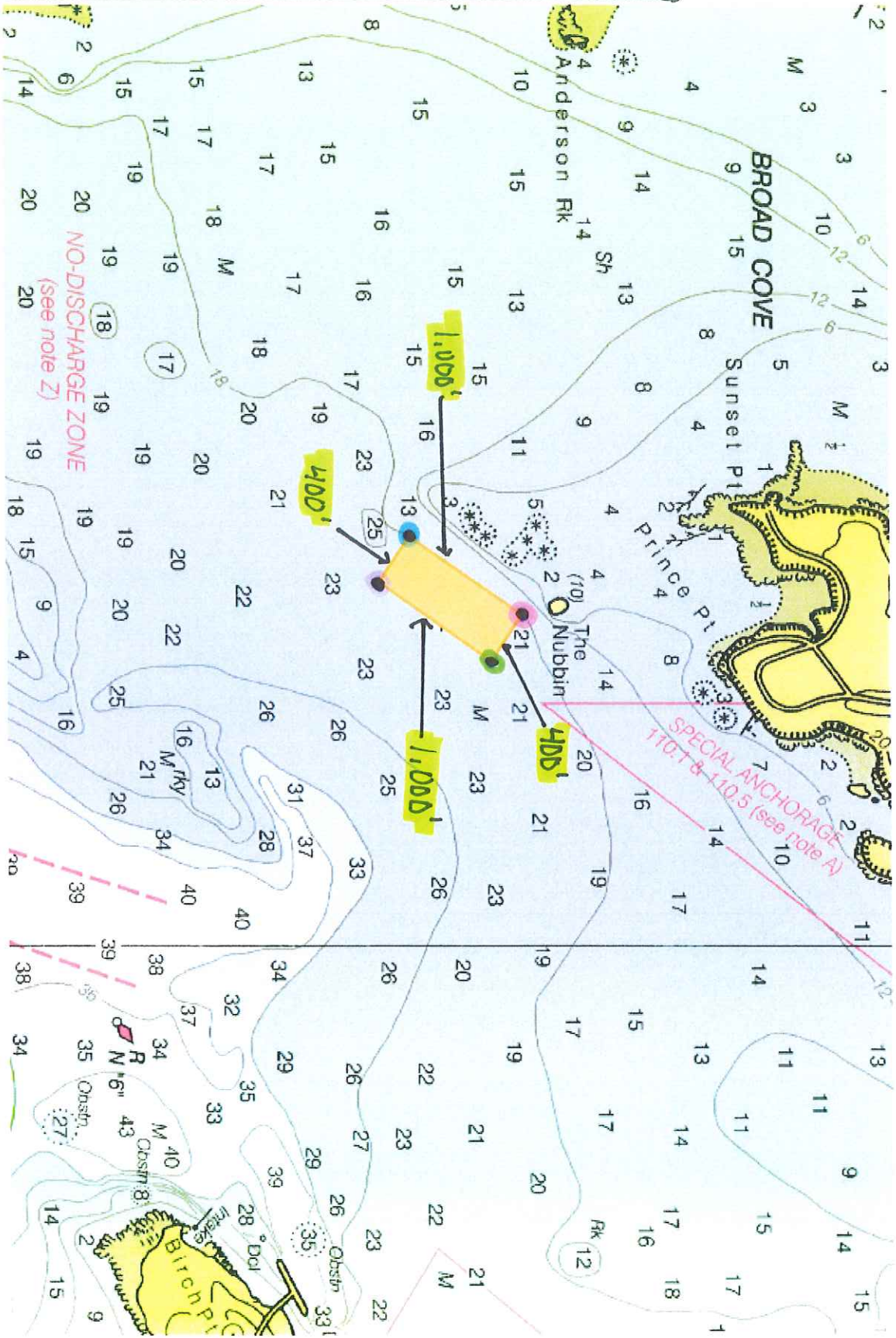

# COORDINATE DESCRIPTION: <sup>FROM QUESTION 6</sup>

● NW = 43.757561  
 -70.175711  
● NE = 43.756951  
 -70.174431

● SW = 43.755297  
 -70.177856  
● SE = 43.754693  
 -70.176590

= LEASE BOUNDARY

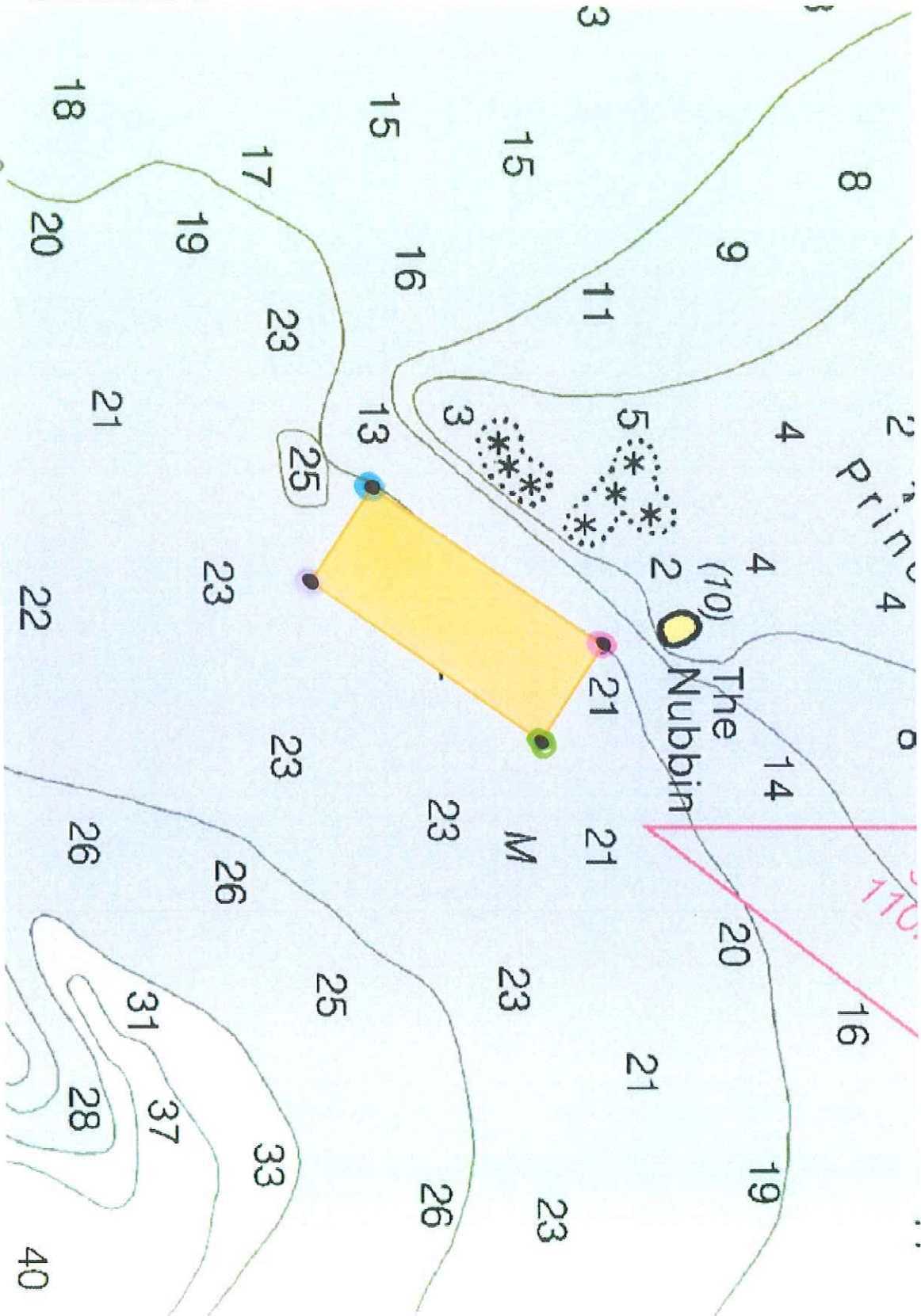



# GEAR DRAWING - DEPTH CONTROL

## BUOY:

FROM QUESTION 7A.

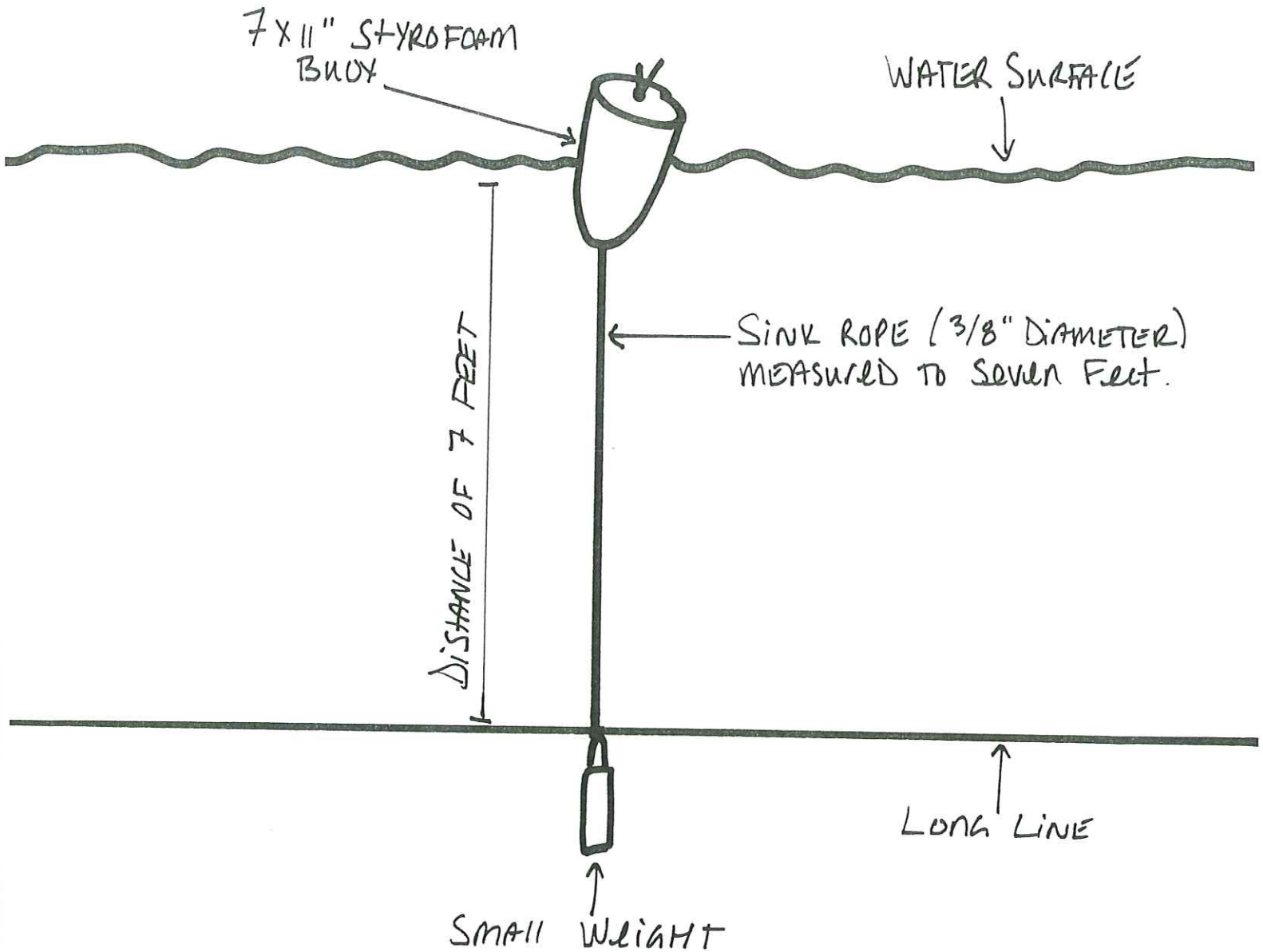

# GEAR DRAWING- SINK ROPE FOR DEPTH CONTROL BHOYS:

---

FROM QUESTION 7A.

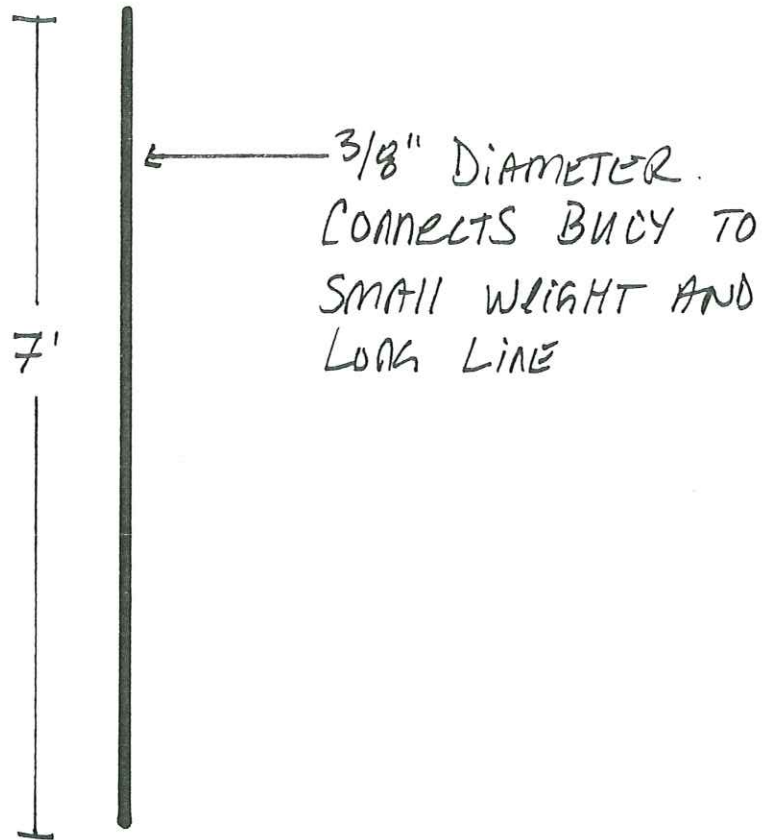

# GEAR DRAWING - SMALL WEIGHT FOR DEPTH CONTROL BHOYS:

---

FROM QUESTION 7A.

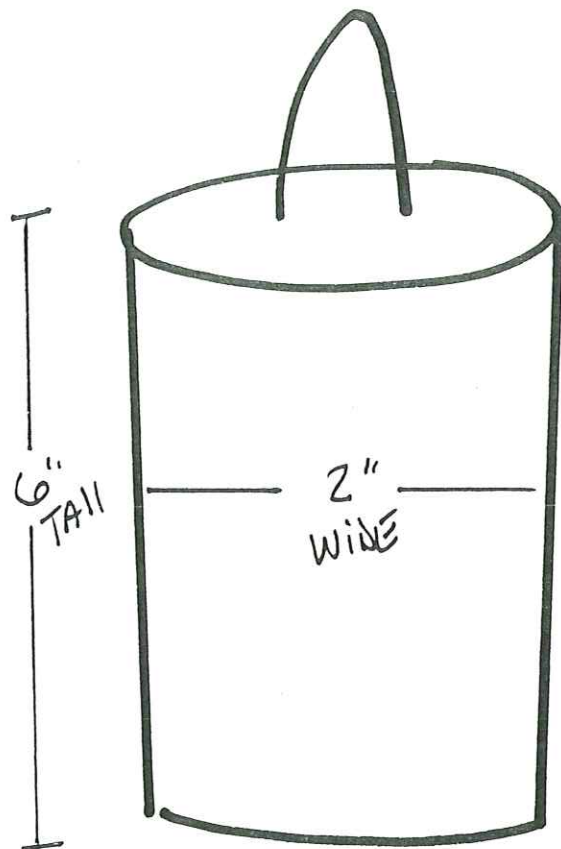

# GEAR DRAWING - LONG LINE:

---

FROM QUESTION 7A.

---

↑  
7/16" DIAMETER  
600' = TOTAL LENGTH OF  
EACH LONG LINE

# GEAR DRAWING - MOORING MARKER:

---

FROM QUESTION 7A

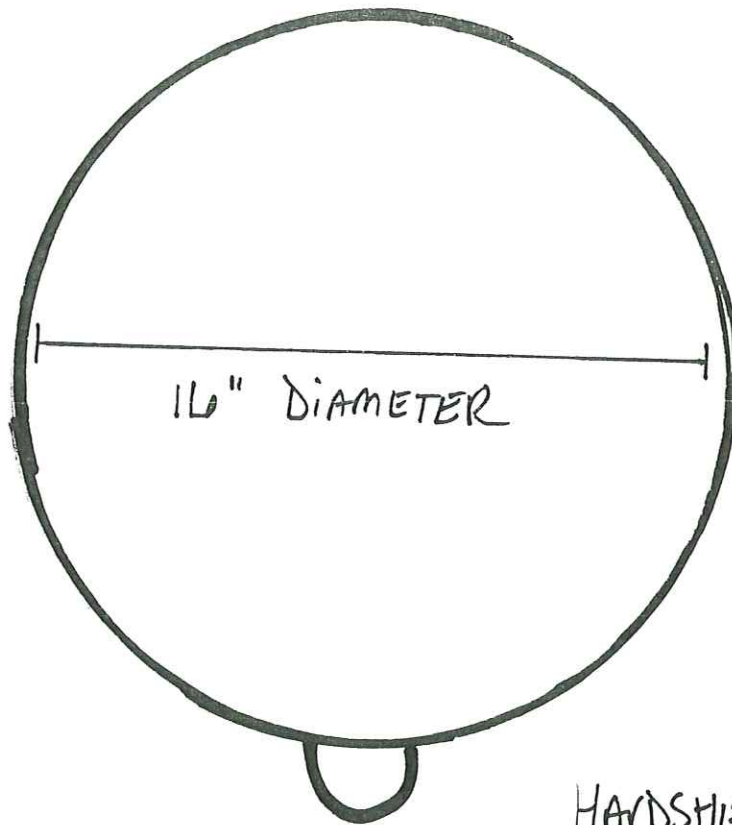

HARDSTEEL 60 DEEP  
(white)

# LEAF DRAWING - MOORING LINE:

FROM QUESTION 7A.

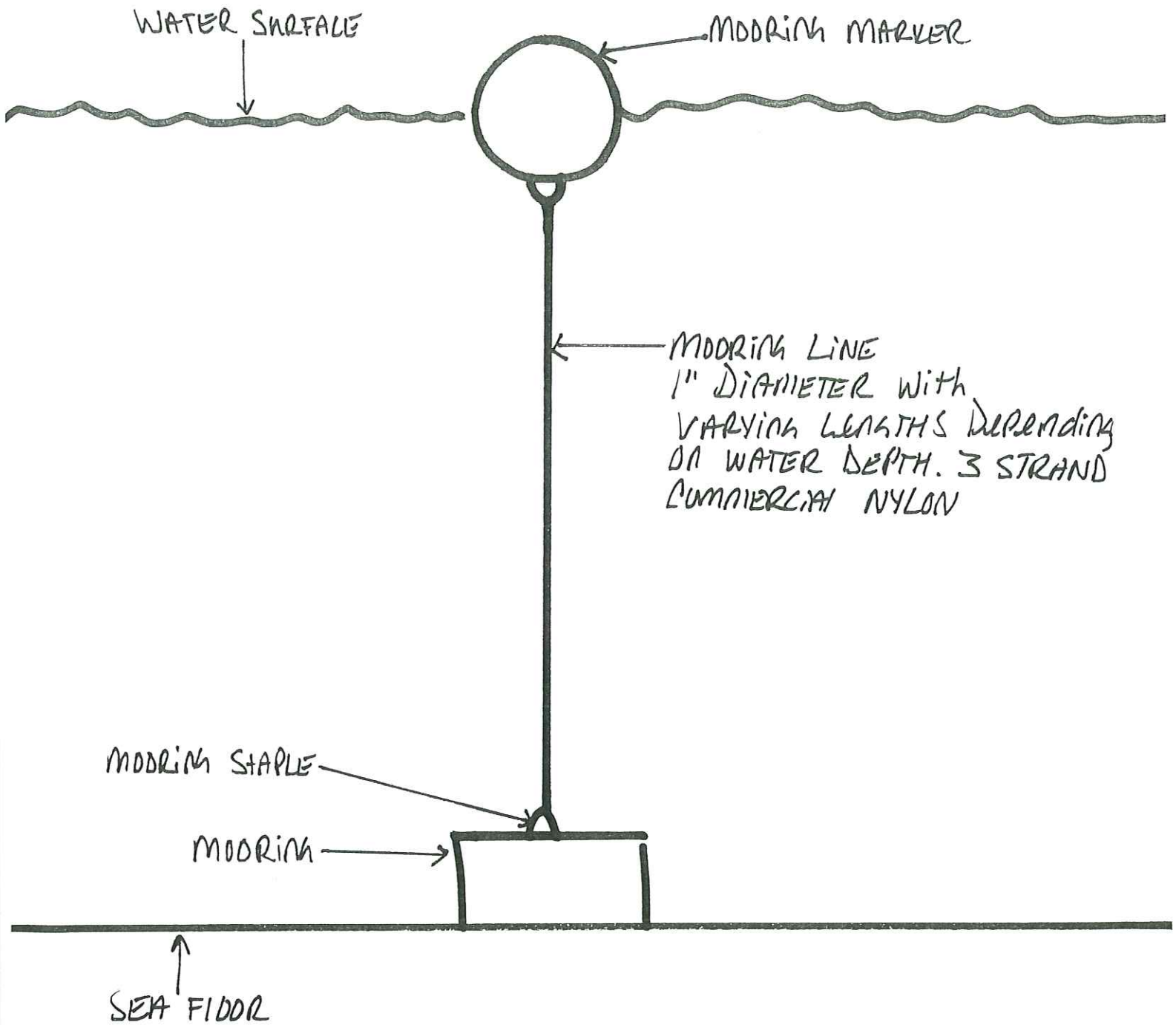

# GEAR DRAWING-MOORING:

FROM QUESTION 7A

Concrete Block  $\approx$  1,150 lbs.

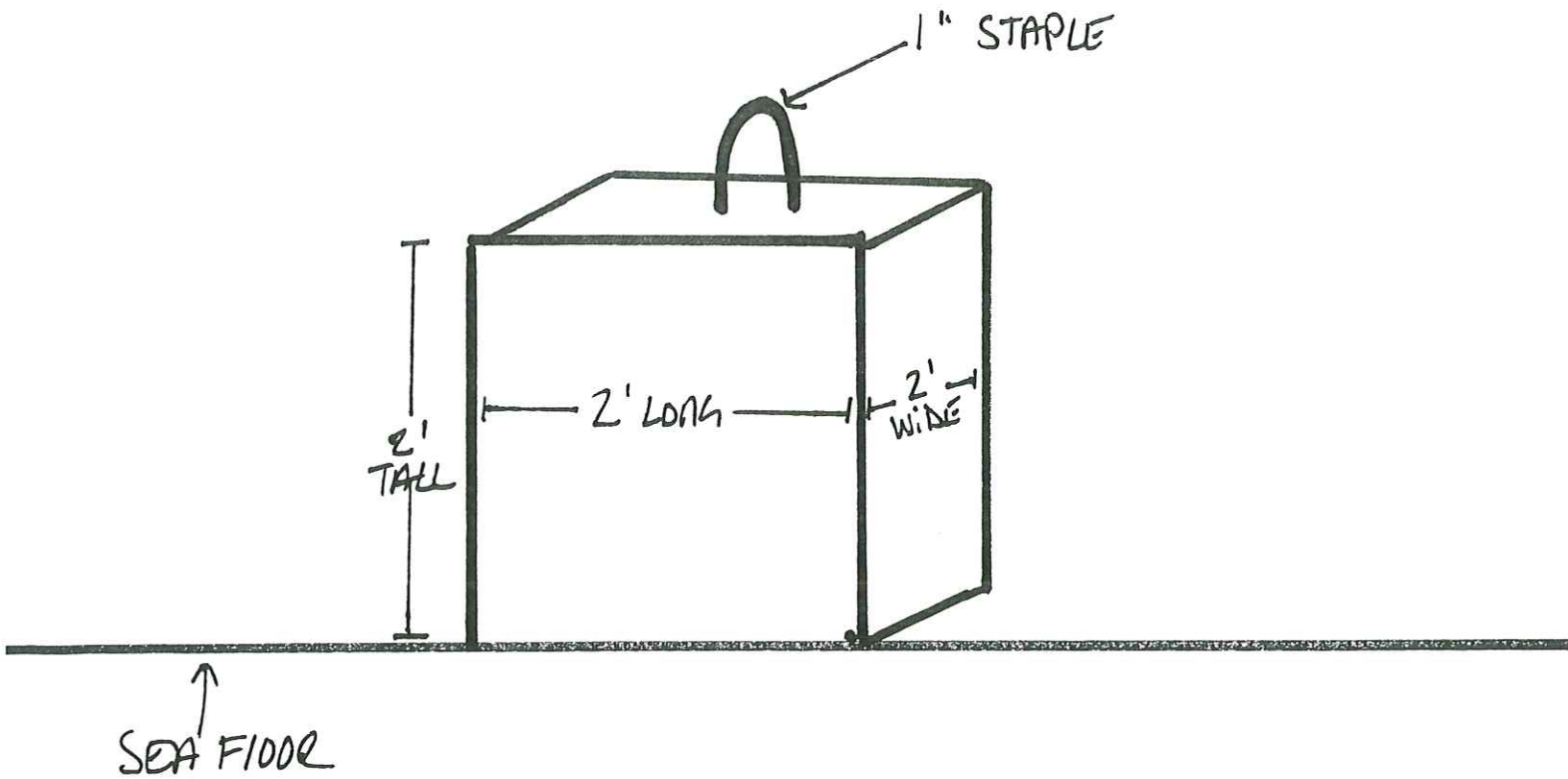

# GEAR DRAWING-MOORING STAPLE:

---

FROM QUESTION 7A

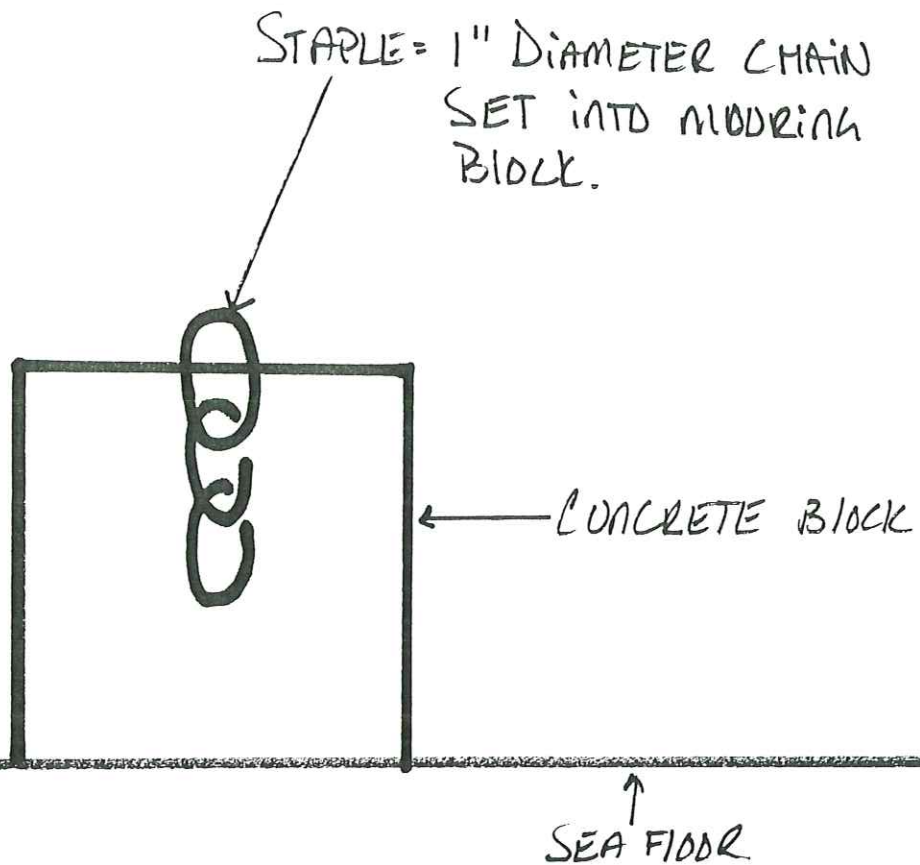



# GEAR DRAWING - LINE CONNECTING

## MOORINGS:

FROM QUESTION 7A

\* JUNE 1<sup>ST</sup> - NOV 1<sup>ST</sup>  
WHEN MOORING TACKLE  
IS OUT OF WATER.

WATER SURFACE



1/2" LINE CONNECTING  
MOORINGS TOGETHER

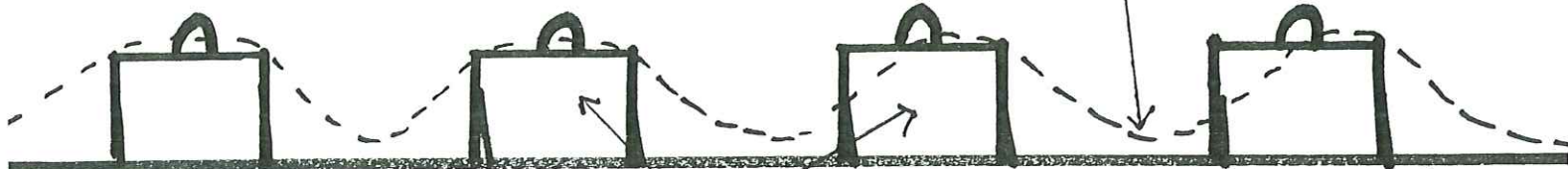

MOORINGS

SEA FLOOR

# GEAR DRAWING - SHACKLE:

FROM QUESTION 7A.

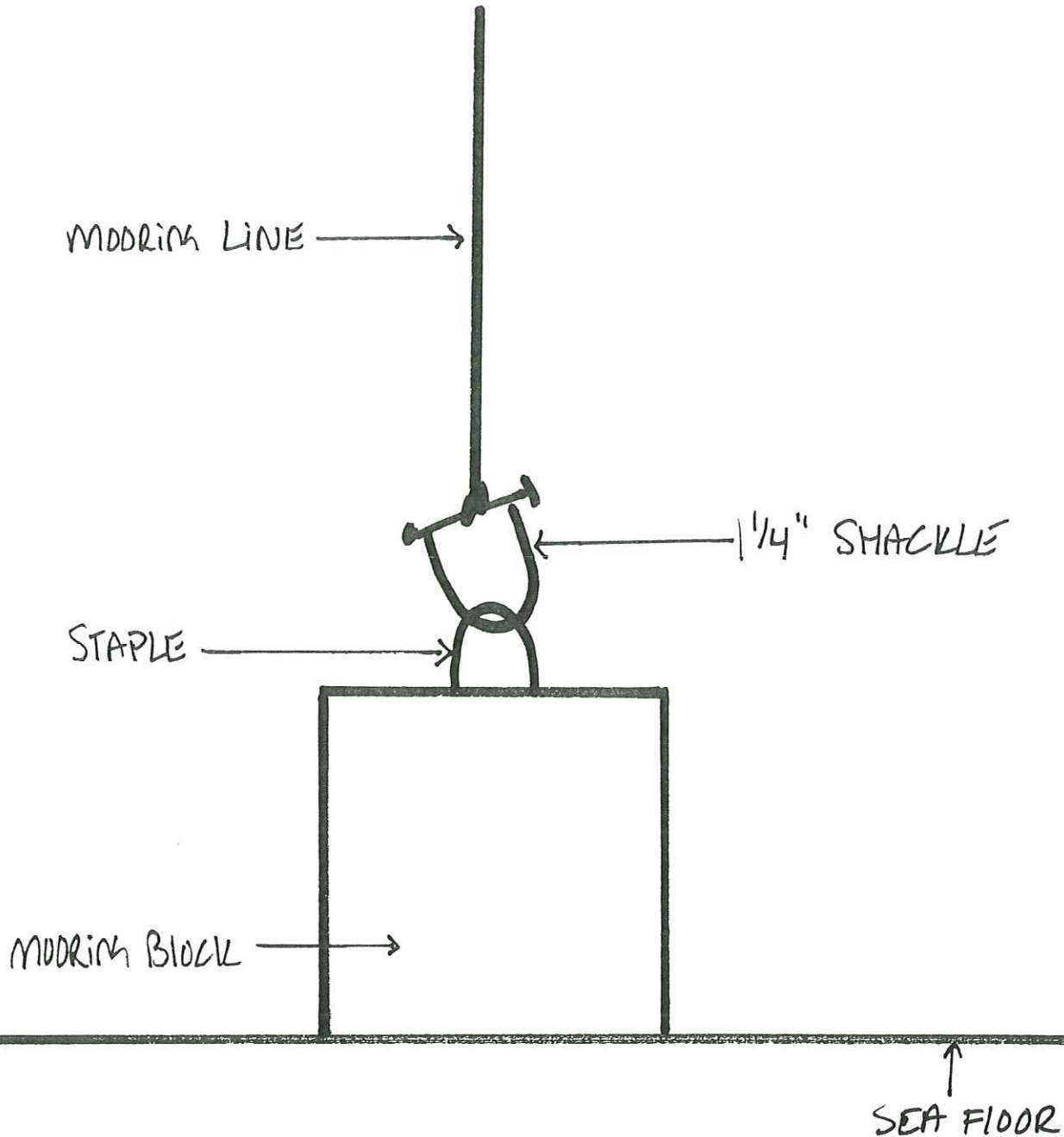

# GEAR DRAWING: CORNER MARKING MARKER

FROM QUESTION 7.A

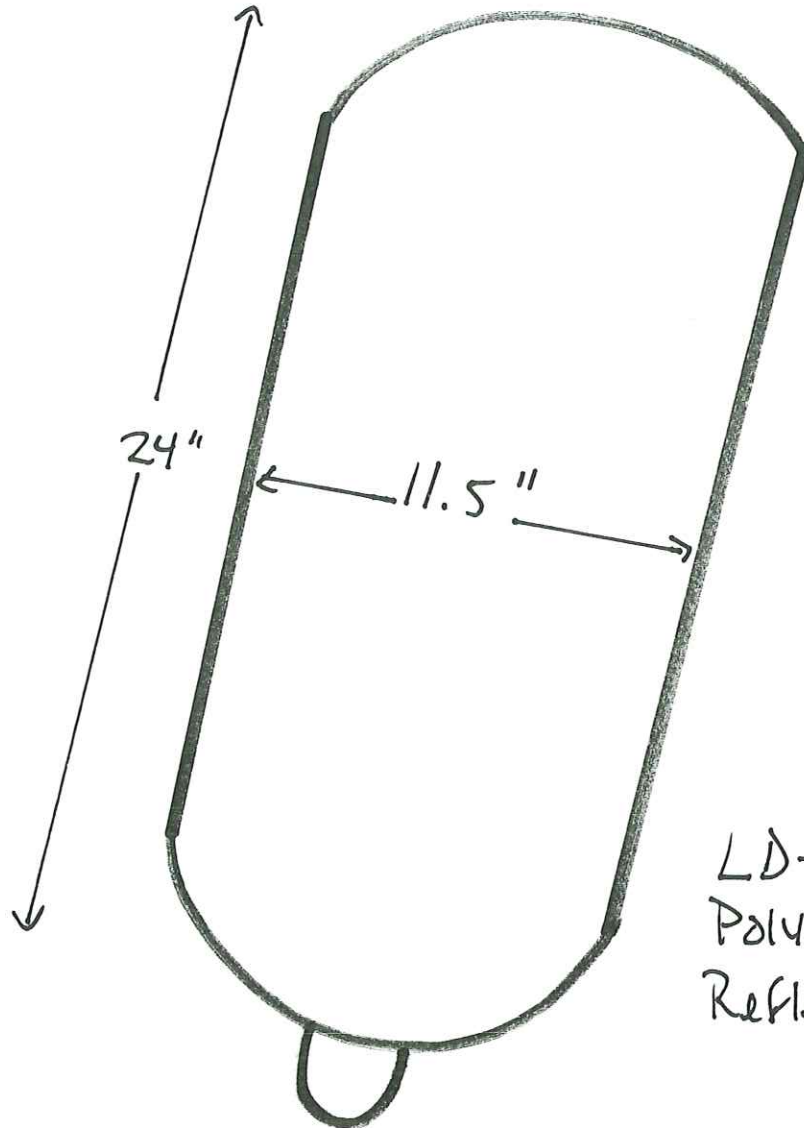

LD-2 YELLOW  
POLY BALL WITH  
REFLECTIVE TAPE

# OVERHEAD VIEW:

FROM QUESTION 7B

NOV 1ST - JUNE 1ST

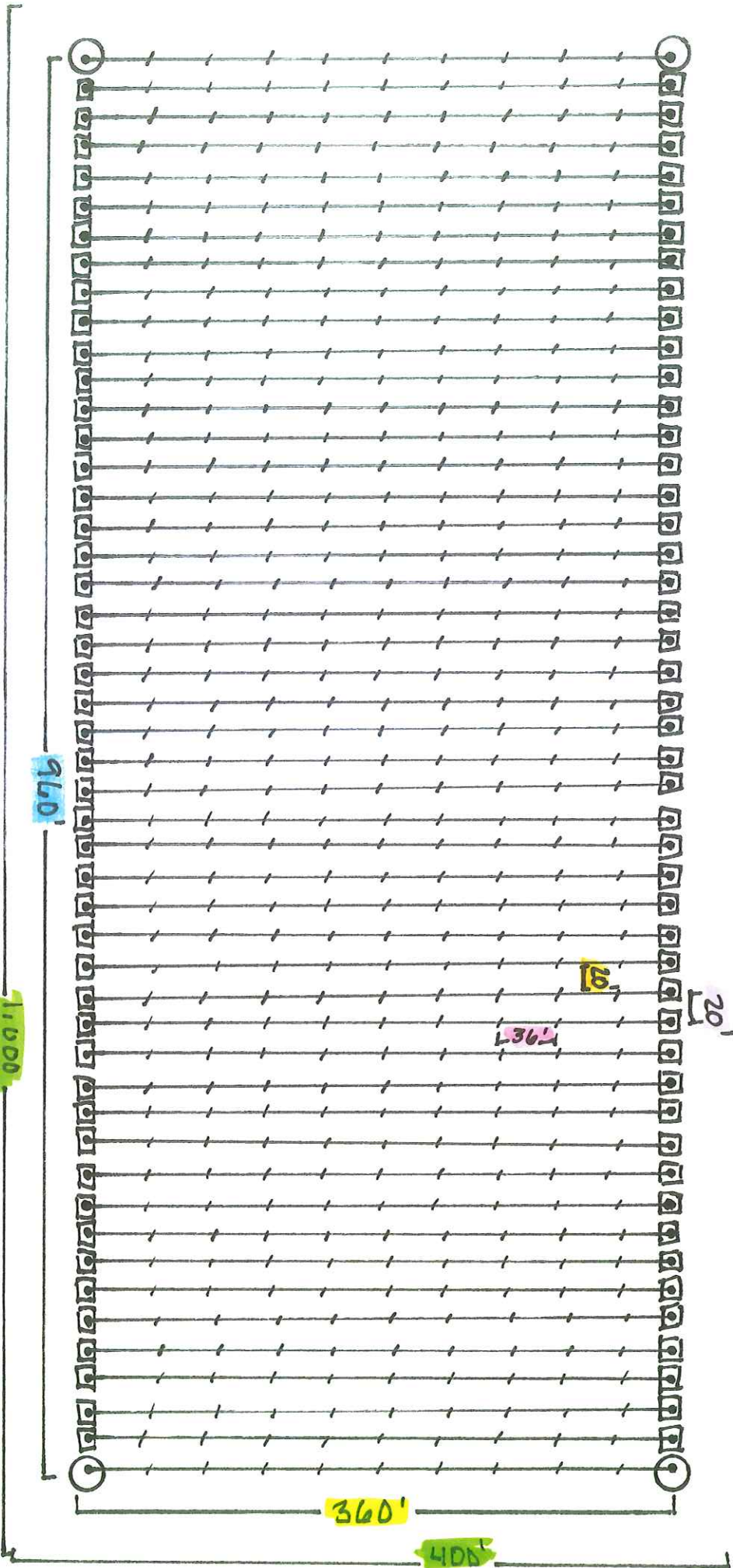

# KEY FOR OVERHEAD VIEW:

FROM QUESTION 7B

- ⊙ = CORNER MOORING MARKERS
- = MOORING MARKER WITH MOORING LINE
- = MOORING
- | = LONG LINE
- X = DEPTH CONTROL BUOY
- = DISTANCE BETWEEN DEPTH CONTROL BUOYS (36')
- = LENGTH OF LONG LINE
- = LENGTH OF MOORING ROW AND LINE CONNECTING MOORINGS (960')
- = DISTANCE BETWEEN MOORINGS (20')
- = DISTANCE BETWEEN LONG LINES (20')
- = PERIMETER MEASUREMENTS.

# NET HEAD VIEW SEASONAL CHANGES:

FROM QUESTION 7B

JUNE 1<sup>ST</sup> - NOV 1<sup>ST</sup>

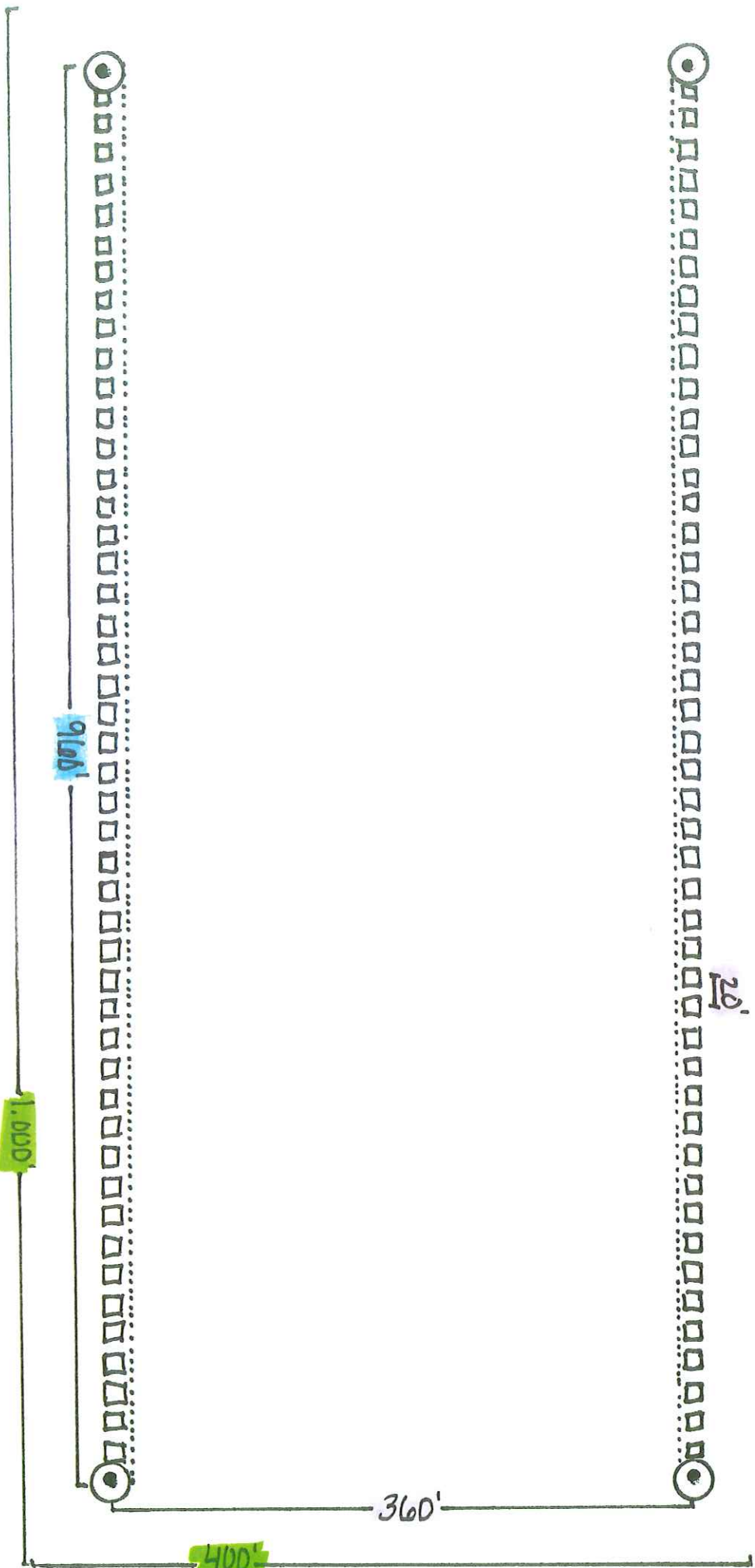

# KEY FOR OVERHEAD VIEW

## SEASONAL CHANGES:

FROM QUESTION 7B.

⊙ = CORNER MOORING MARKERS

□ = MOORING

..... = LINE CONNECTING MOORINGS

||| = DISTANCE BETWEEN MOORINGS

— = LENGTH OF MOORING ROW AND LINE CONNECTING MOORINGS

— = PERIMETER MEASUREMENTS

# CROSS-SECTION VIEW:

NOV 2<sup>ST</sup> - JUNE 1<sup>ST</sup>

FROM QUESTION 7B

WATER SURFACE

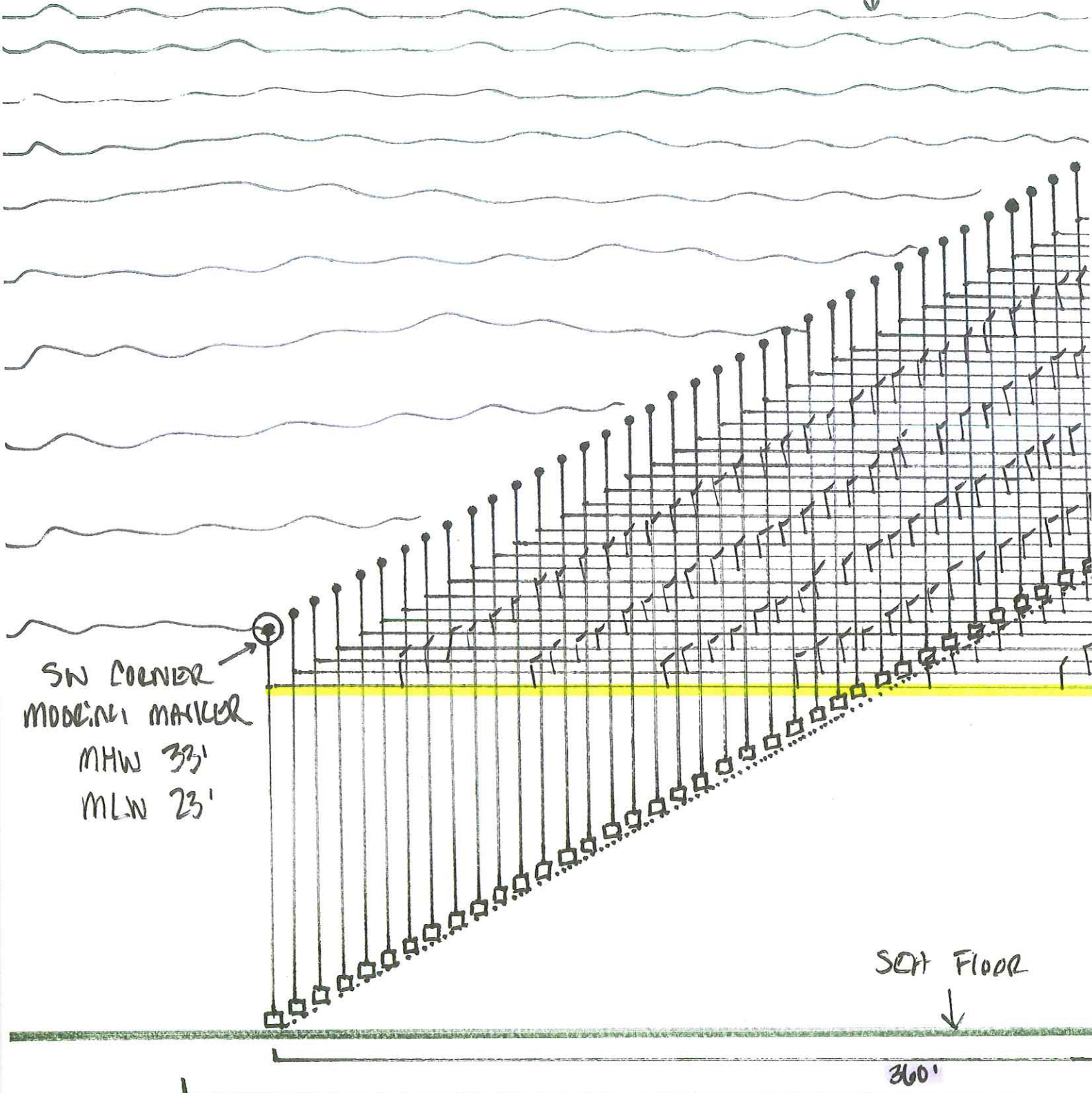

SW CORNER  
MODERN MARKER  
MHW 33'  
MLW 23'

SEA FLOOR



360'

400'



NW CORNER  
MOORING MARKER  
MHW 31'  
MLW 21'

NOV 1<sup>ST</sup> - JUNE 1<sup>ST</sup>

WATER SURFACE

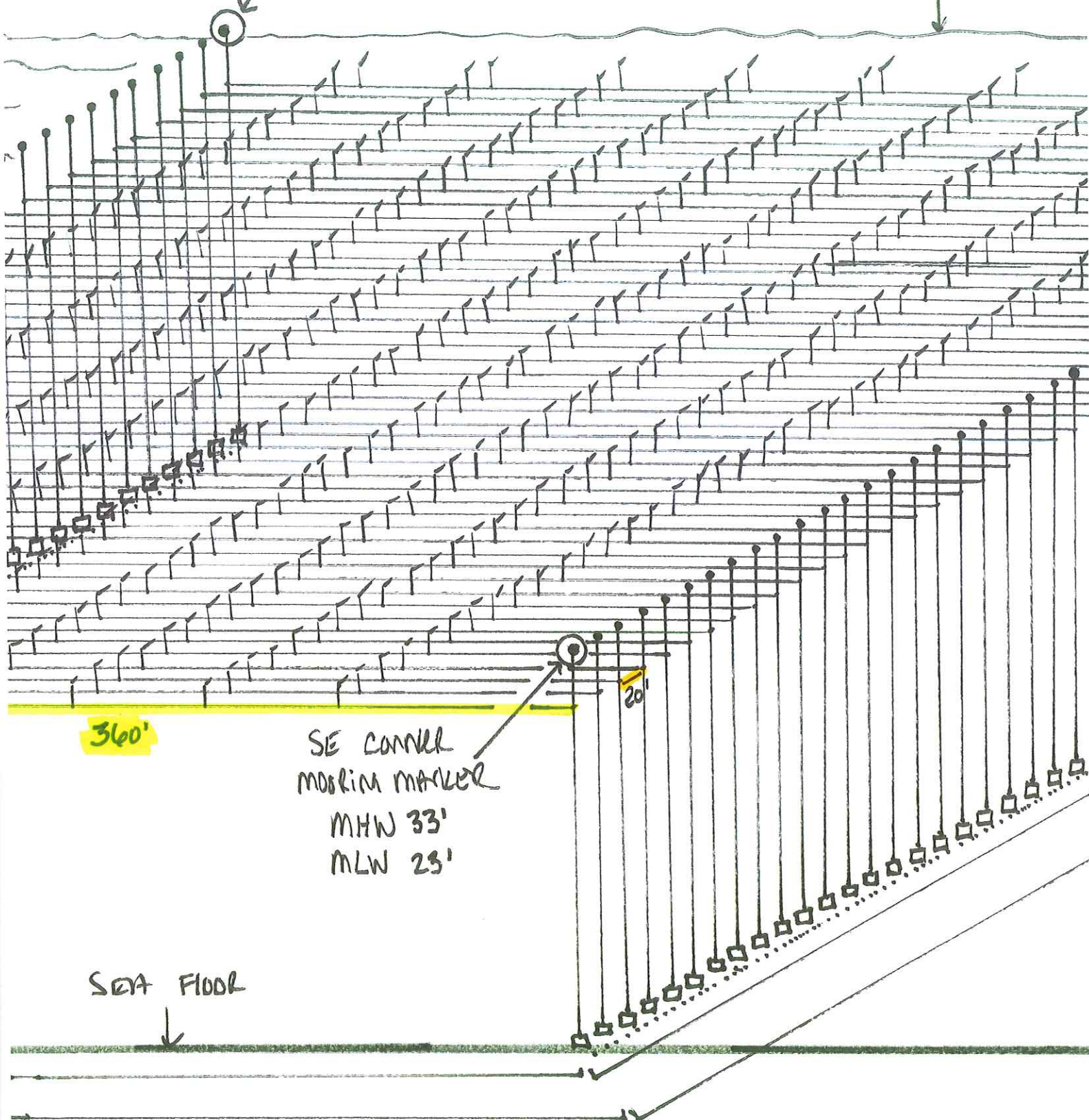

360'

SE CORNER  
MOORING MARKER  
MHW 33'  
MLW 23'

20'

SEA FLOOR

NOV 1<sup>ST</sup> - JUNE 1<sup>ST</sup>

NE CORNER  
MOORING MARKER  
MHW 33'  
MLW 23'

WATER  
SURFACE  
↓

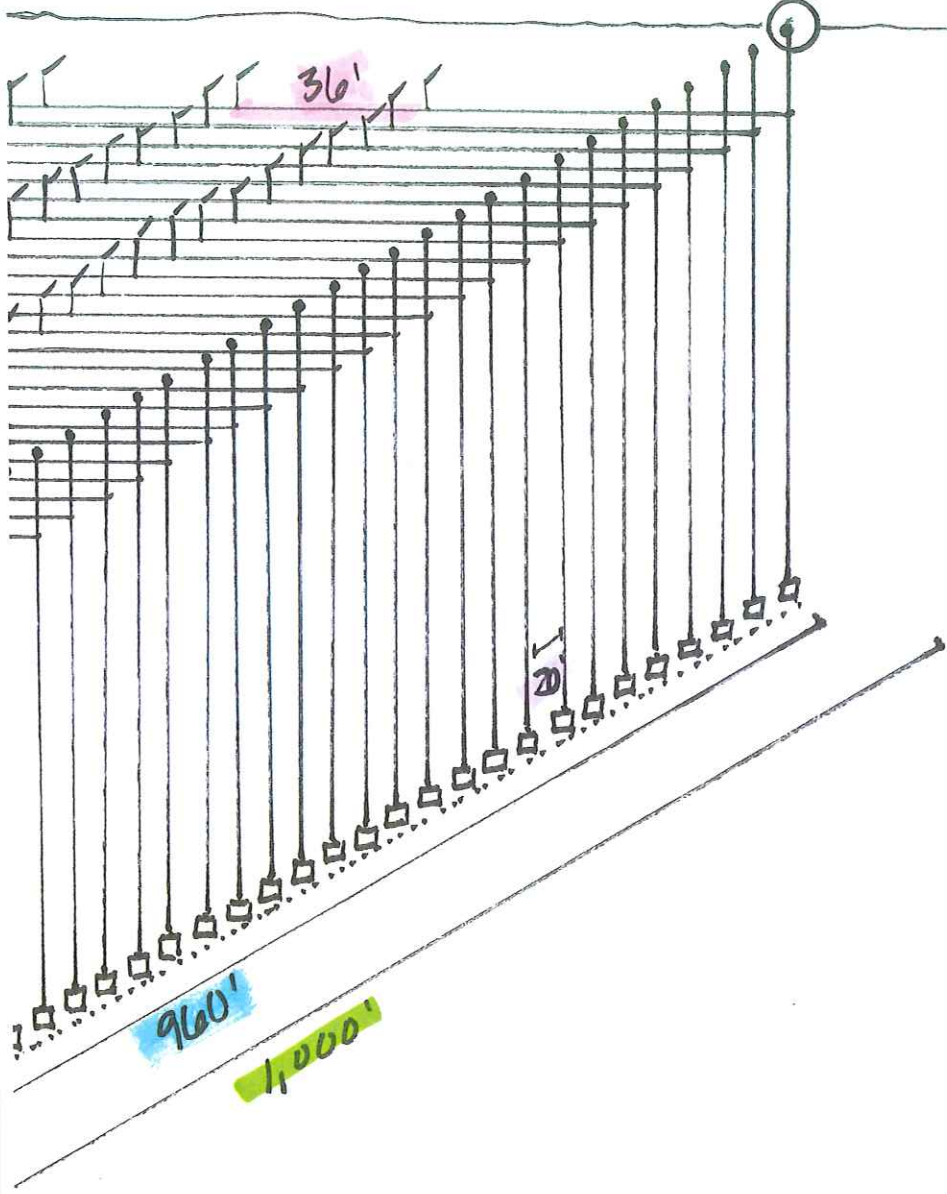

SEA FLOOR  
↓

# KEY FOR CROSS-SECTION VIEW:

FROM QUESTION 7B

⊙ = CORNER MOORING MARKER

• = MOORING MARKER

| = MOORING LINE

□ = MOORING

..... = LINE CONNECTING MOORINGS

┌ = DEPTH CONTROL BUOYS

— = LONG LINE

— = LENGTH OF LONG LINE

— = DISTANCE BETWEEN DEPTH CONTROL BUOYS

— = DISTANCE BETWEEN LONG LINES

— = DISTANCE BETWEEN MOORINGS

— = LENGTH OF MOORING ROW AND LINE CONNECTING MOORINGS

— = PERIMETER MEASUREMENTS

# CROSS-SECTION VIEW SEASONAL CHANGES:

JUNE 1<sup>ST</sup> - NOV 1<sup>ST</sup>

FROM QUESTION 7B

WATER SURFACE

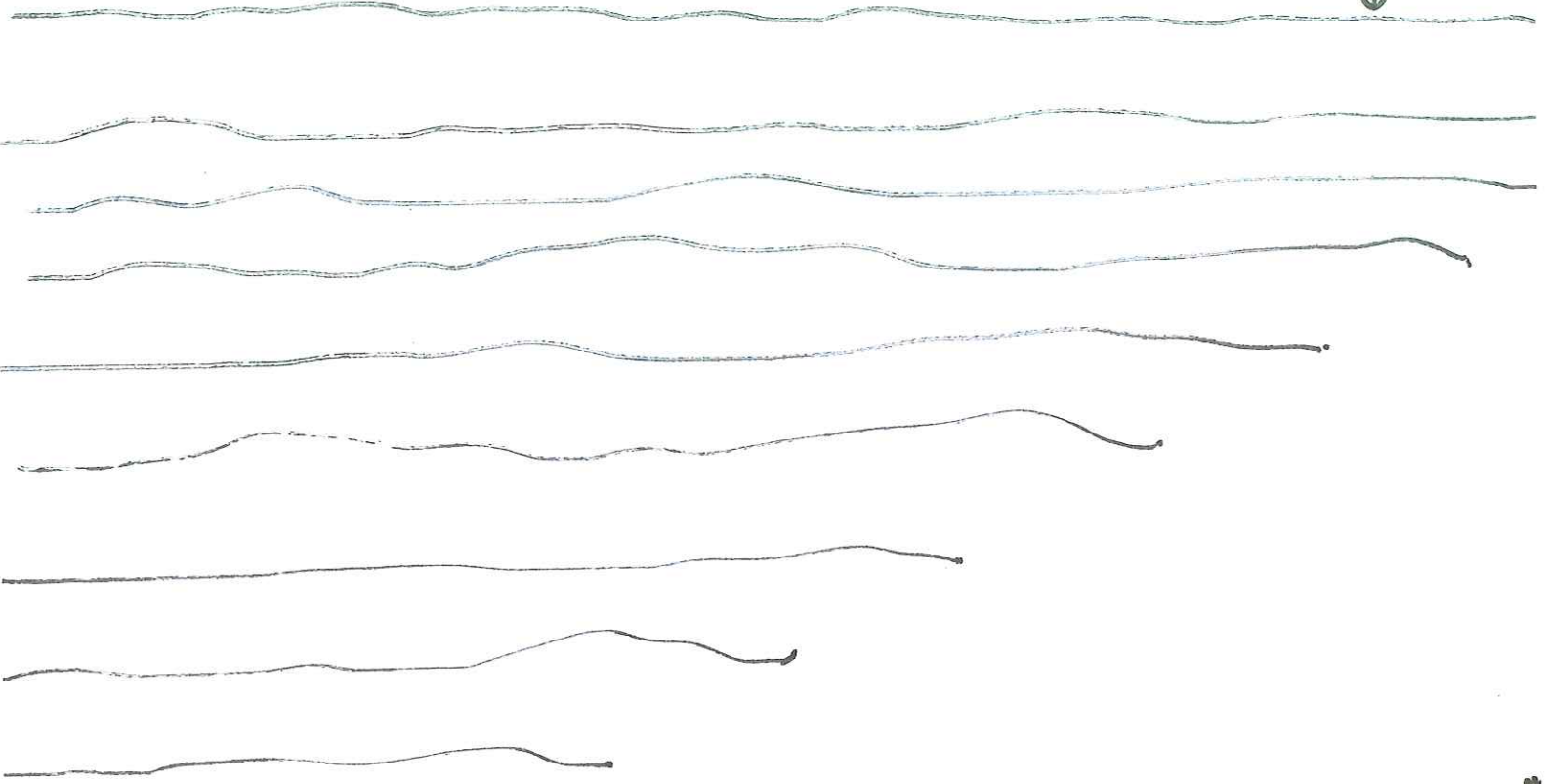

SW CORNER  
MOORING MARKER  
MHW 53'  
MLW 23'

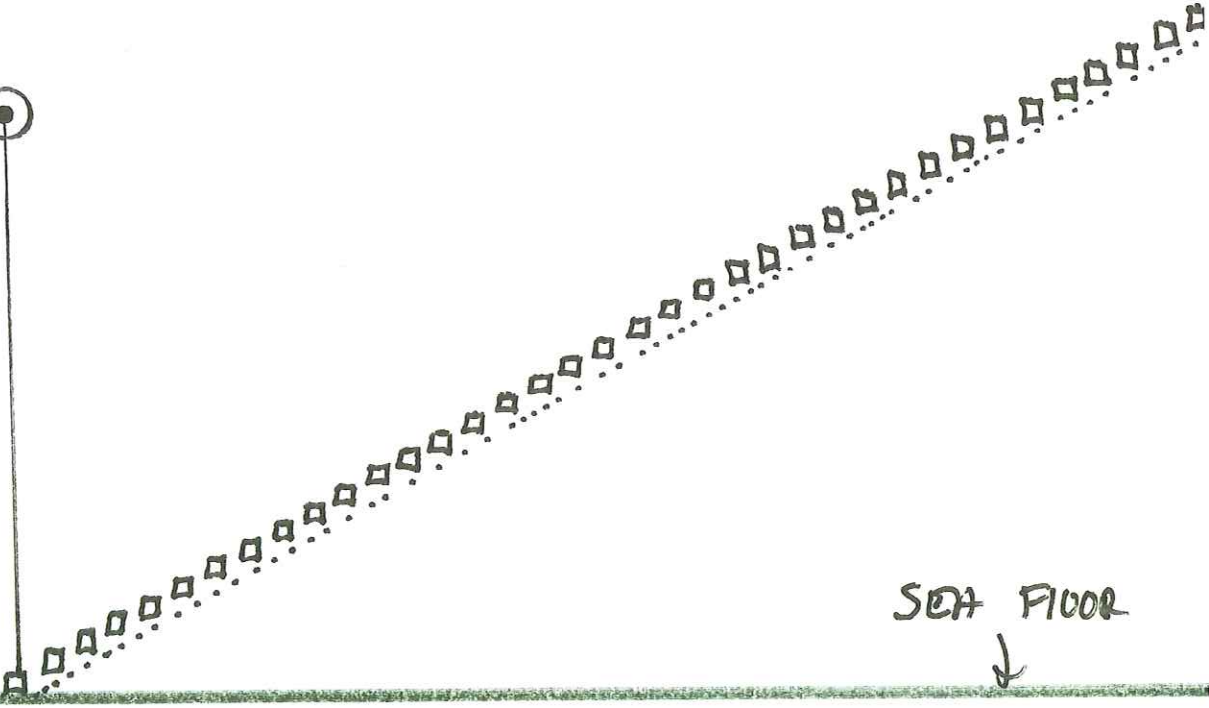

SEA FLOOR



360'

400'

JUNE 1<sup>ST</sup> - NOV 1<sup>ST</sup>

NW CORNER  
MOORING MARKER

MHW 31'  
MLW 21'

WATER SURFACE

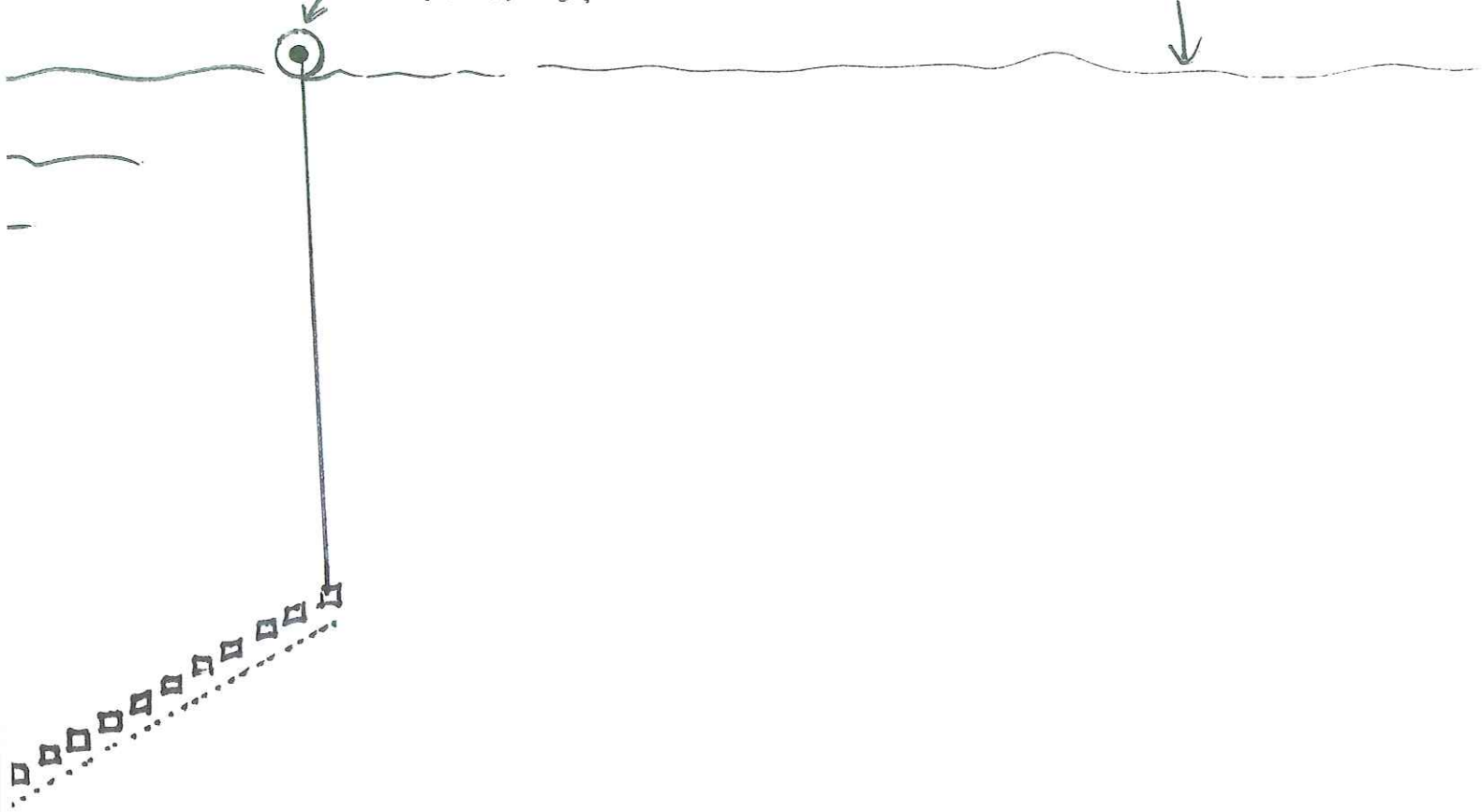

SE CORNER  
MOORING MARKER

MHW 33'  
MLW 23'

SEA FLOOR

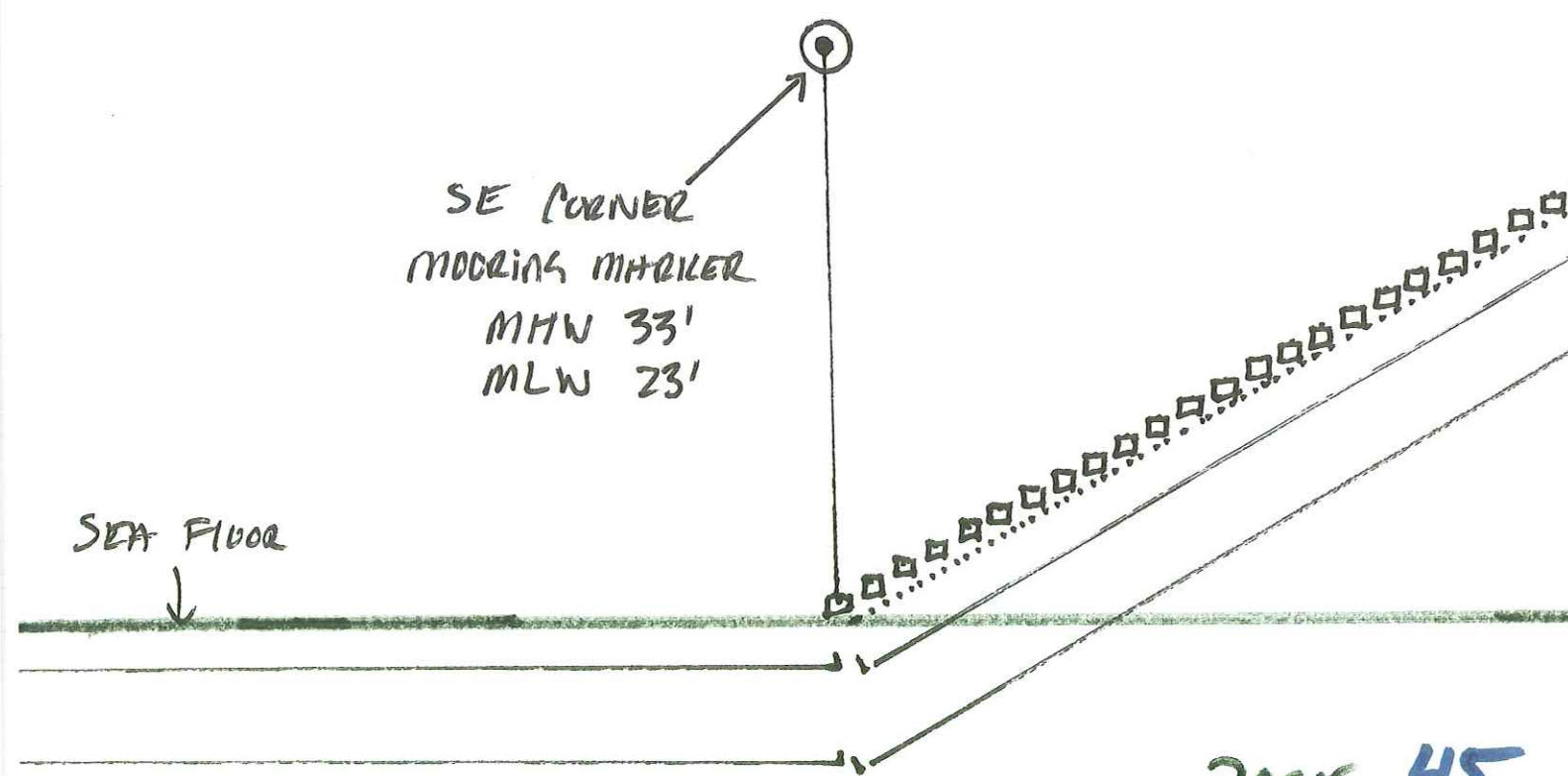

NE CORNER  
MOORING MARKER  
MHW 3.3'  
MLW 2.3'

JUNE 1<sup>ST</sup> - NOV 1<sup>ST</sup>

WATER SURFACE  
↓

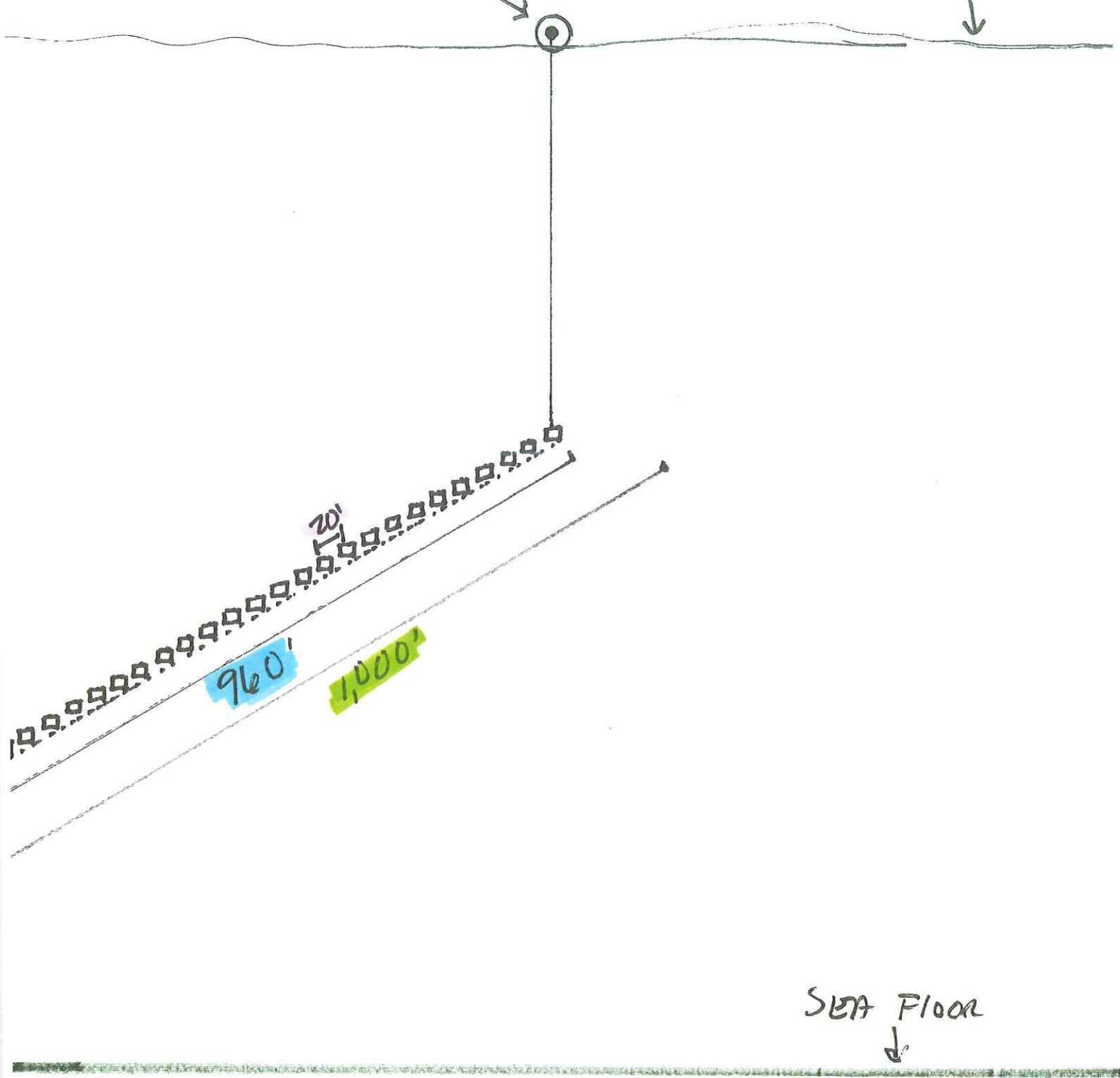

# KEY FOR CROSS-SECTION VIEW SEASONAL CHANGES:

---

FROM QUESTION 7B

⊙ = CORNER MOLDING MARKER

| = MOLDING LINE

□ = MOLDINGS

..... = LINE CONNECTING MOLDINGS

— = DISTANCE BETWEEN MOLDINGS

— = LENGTH OF MOLDING ROW AND LINE  
CONNECTING MOLDINGS

— = PERIMETER MEASUREMENTS

# EQUIPMENT LAYOUT 1:

FROM QUESTION 7.1E

PHOTO TAKEN: 4/30/22



NW 1<sup>st</sup> - JUNE 1<sup>st</sup>

Sent from Yahoo Mail for iPhone

● = CORNER MOORING MARKERS

"white circles" = MOORING MARKERS

/ = DEPTH CONTROL BUOYS (will be white in real life)

\* View looking South From the Nubbin



# EQUIPMENT LAYOUT 2:

FROM QUESTION 7.E

PHOTO TAKEN: 4/30/22.



NOV 1ST - JUNE 1ST

Sent from Yahoo Mail for iPhone

● = CORNER MOORING MARKERS

"white circles" = MOORING MARKERS

/ = DEPTH CONTROL BUOYS (will be white in real life)

\* View looking NORTH TOWARDS THE NUBBIN

# TAX MAP:

From QUESTION 14.A



= ESTIMATED LEASE BOUNDARY



JANET T. MILLS  
GOVERNOR

STATE OF MAINE  
DEPARTMENT OF MARINE RESOURCES  
21 STATE HOUSE STATION  
AUGUSTA, MAINE  
04333-0021

PATRICK C. KELIHER  
COMMISSIONER

**- RIPARIAN OWNERS LIST -**

*THIS LIST MUST BE CERTIFIED BY THE TOWN CLERK*

On this list, please include the map number, lot number, and the current owners' names and mailing addresses for all shorefront parcels within 1,000 feet of the lease site. It is the applicant's responsibility to assemble the information for the Town Clerk to certify. The Town Clerk *only* certifies that the information is correct according to the Town's records. Once you have completed the form, ask the Town Clerk to complete the certification section below. If riparian parcels are located within more than one municipality, provide a separate, tax map and certified riparian list for each municipality.

TOWN OF: YARMOUTH, MAINE

MAP #	LOT #	Landowner name(s) and address(es)
<u>1</u>	<u>27</u>	<u>THE STATE OF MAINE</u>

**Please use additional sheets if necessary and attach hereto.**

**CERTIFICATION**

I, Reith A. Bennett Deputy, Town Clerk for the Town of Yarmouth, certify that the names and addresses of the property owners listed above, as well as the map and lot numbers, are those listed in the records of this municipality and are current as of this date.

SIGNED: Reith A. Bennett Deputy DATE: 4/11/22

**PAGE  
52**

Maine Department of Marine Resources:

Colleen Francke and Summit Point LLC obtained \$75,000 of revolving credit through FarmStart, LLP in 2019. These funds were established to help Colleen start-up her aquaculture business in Southern Maine. Colleen has been in good credit and member standing since origination, and there are no issues to report.

Thank you,

Kathryn

Kathryn Bisson

FarmStart Advisor at  
Farm Credit East  
615 Minot Avenue  
Auburn, ME 04210



**MAINE DEPARTMENT OF MARINE RESOURCES**  
*Aquaculture Division, 21 State House Station, Augusta, ME 04333-0021 (207) 624-6567*

**CORPORATE APPLICANT FORM**  
**For Standard and Experimental Aquaculture Lease Applications**

Corporations or partnerships that apply for aquaculture leases in the State of Maine must complete this form. Corporations must submit information as requested under A. Corporate Applicant. Partnerships must submit information as requested under B. Partnership Applicant.

**A. Corporate Applicant**

**Note:** You must attach a copy of the Articles of Incorporation (Inc.) or Certificate of Formation (LLC) to your application.

1. Name of Corporation: Summit Point LLC  
 2. Date of incorporation: 1/4/2017 State of incorporation: Maine

3. List the names, addresses, and titles of all officers:

Name	Address	Title
Colleen Francke	1 Shady Lane Falmouth, ME. 04105	Owner

**Please use additional sheets if necessary and attach to the application.**

4. List the names and addresses of all directors/members:

Name	Address
Colleen Francke	1 Shady Lane Falmouth, ME. 04105

**Please use additional sheets if necessary and attach to the application.**

5. Has the corporation, or any stockholder, director, or officer applied for an aquaculture lease for Maine lands in the past?  Yes  No

If you selected "yes," please indicate who applied for the lease and the status of the application or lease.

-Colleen Francke on behalf of Summit Point LLC.  
For lease area CAS SI2. Lease was granted and is active.

6. List the names and addresses of all stockholders who own or control at least 5% of the outstanding stock and the percentage of outstanding stock currently owned or controlled by each stockholder.

Name	Address	Percentage of Owned Stock
Colleen Francke	1 Shady Lane Falmouth, ME. 04105	100%

**Please use additional sheets if necessary and attach to the application.**

7. List the names and addresses of stockholders, directors, or officers owning an interest, either directly or beneficially, in any other Maine aquaculture leases, as well as the quantity of acreage from existing aquaculture leases attributed to each such person based on the percentage of owned stock listed in question 6. If none, write, "None."

Name	Address	Lease Acronym	Acreage
Colleen Francke	1 Shady Lane Falmouth, ME. 04105	CAS SI2	10.38

**Please use additional sheets if necessary and attach to the application.**

8. Has the corporation or any officer, director, member, or shareholder listed in item 5 above ever been arrested, indicted, convicted of, or adjudicated to be responsible for any violation of any marine resources or environmental protection law, whether state or federal?

Yes  No

If you selected "yes", please provide details.

**B. Partnership Applicant**

**Note:** You must attach a copy of either the Certificate of Limited Partnership or documentation of the formation of a General Partnership to your application.

1. Name of Partnership: NA

2. Date of formation: NA State of partnership: NA

3. List the names, addresses, and ownership shares of all partners:

Name	Address	Ownership Shares
NA		

**Please use additional sheets if necessary and attach to the application.**

4. Has the partnership, or any partner applied for an aquaculture lease for Maine lands in the past?  Yes  No NA

If you selected "yes," please indicate who applied for the lease and the status of the application or lease.

5. List the names and addresses of any partner owning an interest, either directly or beneficially, in any other Maine aquaculture leases, as well as the quantity of acreage from existing aquaculture leases attributed to each such person, based on their ownership shares from question 3.

Name	Address	Lease Acronym	Acreage
NA			

Please use additional sheets if necessary and attach to the application.

6. Has the partnership or any partner been arrested, indicted or convicted of or adjudicated to be responsible for any violation of marine resources or environmental protection law, whether State or Federal?

Yes  No NA

If you selected "yes", please provide details.



MAINE  
LIMITED LIABILITY COMPANY

STATE OF MAINE

CERTIFICATE OF FORMATION

Filing Fee \$175.00

File No. 20173201DC Pages 2  
Fee Paid \$ 175  
DCN 2170172270069 DLLC  
---FILED---  
01/06/2017

  
Deputy Secretary of State

A True Copy When Attested By Signature  
  
Deputy Secretary of State

Pursuant to 31 MRSA §1531, the undersigned executes and delivers the following Certificate of Formation:

FIRST: The name of the limited liability company is:  
**Summit Point LLC**

(A limited liability company name must contain the words "limited liability company" or "limited company" or the abbreviation "LLC," "LLC," "L.C." or "LC" or, in the case of a low-profit limited liability company, "L3C" or "l3c" - see 31 MRSA 1508.)

SECOND: Filing Date: (select one)

- Date of this filing; or  
 Later effective date (specified here): \_\_\_\_\_

THIRD: Designation as a low profit LLC (Check only if applicable):

- This is a low-profit limited liability company pursuant to 31 MRSA §1611 meeting all qualifications set forth here:
- A. The company intends to qualify as a low-profit limited liability company;
  - B. The company must at all times significantly further the accomplishment of one or more of the charitable or educational purposes within the meaning of Section 170(c)(2)(B) of the Internal Revenue Code of 1986, as it may be amended, revised or succeeded, and must list the specific charitable or educational purposes the company will further;
  - C. No significant purpose of the company is the production of income or the appreciation of property. The fact that a person produces significant income or capital appreciation is not, in the absence of other factors, conclusive evidence of a significant purpose involving the production of income or the appreciation of property; and
  - D. No purpose of the company is to accomplish one or more political or legislative purpose within the meaning of Section 170(c)(2)(D) of the Internal Revenue Code of 1986, or its successor.

FOURTH: Designation as a professional LLC (Check only if applicable):

- This is a professional limited liability company\* formed pursuant to 13 MRSA Chapter 22-A to provide the following professional services:

\_\_\_\_\_  
(Type of professional services)

FIFTH:

The Registered Agent is a: (select either a Commercial or Noncommercial Registered Agent)

Commercial Registered Agent

CRA Public Number: P10059

Nicholas H. Walsh

(Name of commercial registered agent)

Noncommercial Registered Agent

\_\_\_\_\_  
(Name of noncommercial registered agent)

\_\_\_\_\_  
(physical location, not P.O. Box – street, city, state and zip code)

\_\_\_\_\_  
(mailing address if different from above)

SIXTH:

Pursuant to 5 MRSA §105.2, the registered agent listed above has consented to serve as the registered agent for this limited liability company.

SEVENTH:

Other matters the members determine to include are set forth in the attached Exhibit N/A, and made a part hereof.

\*\*Authorized person(s)

Dated 1/4/2017



(Signature of authorized person)

Nicholas H. Walsh

(Type or print name of authorized person)

\_\_\_\_\_  
(Signature of authorized person)

\_\_\_\_\_  
(Type or print name of authorized person)

\*Examples of professional service limited liability companies are accountants, attorneys, chiropractors, dentists, registered nurses and veterinarians. (This is not an inclusive list – see 13 MRSA §723.7)

\*\*Pursuant to 31 MRSA §1676.1.A, Certificate of Formation MUST be signed by at least one authorized person.

The execution of this certificate constitutes an oath or affirmation under the penalties of false swearing under 17-A MRSA §453.

Please remit your payment made payable to the Maine Secretary of State.

Submit completed form to:

Secretary of State  
Division of Corporations, UCC and Commissions  
101 State House Station  
Augusta, ME 04333-0101  
Telephone Inquiries: (207) 624-7752

Email Inquiries: CEC.Corporations@Maine.gov